

# STORM SERIES

## STORM 10

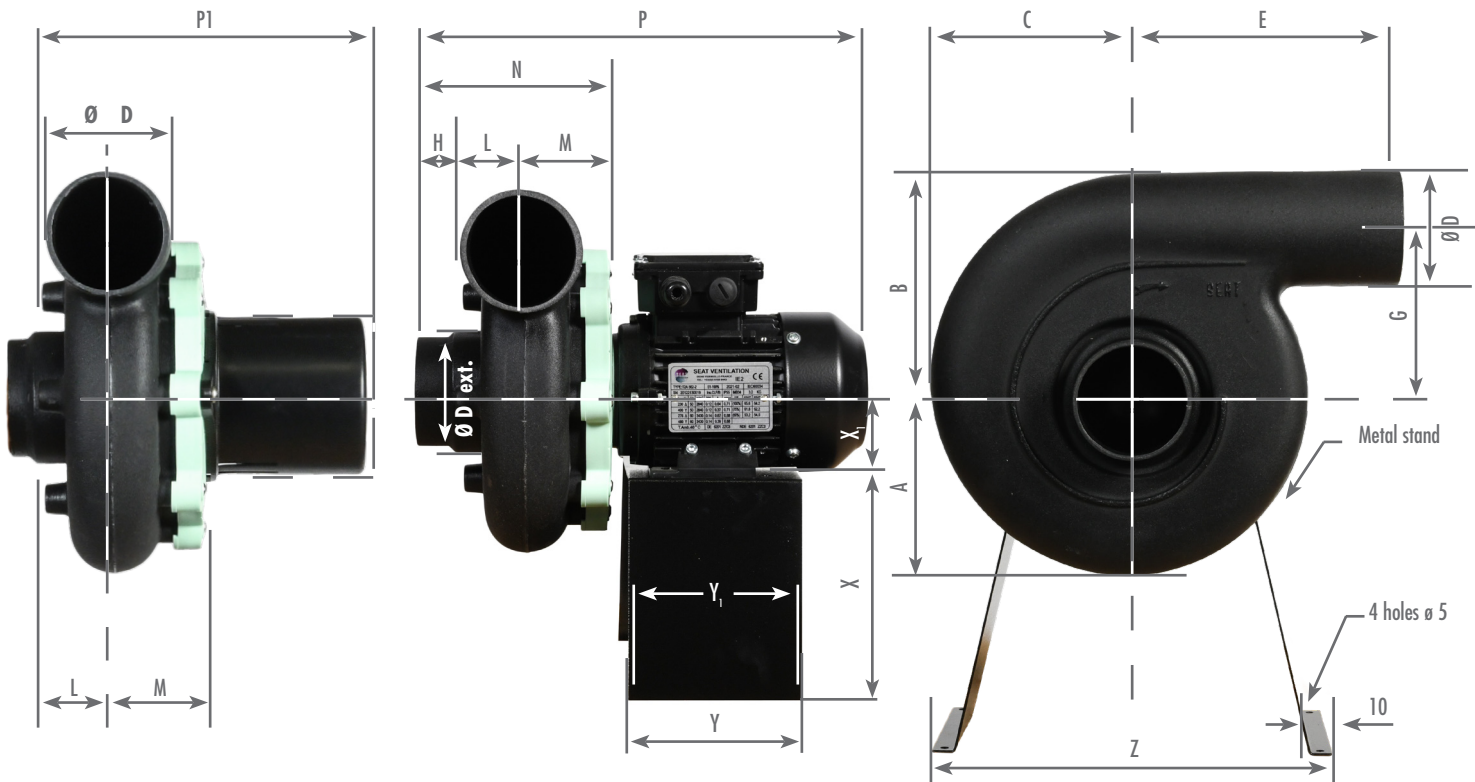

EXTERNAL ROTOR MOTOR VERSION

Available in 

Dimension (mm) - Metal stand not included (see accessories)													
Motor axis heights may vary according to the type of motor used													
A	B	C	ØD	E	G	H	L	M	N	Y	Y <sub>1</sub>	Z	X
115	135	127	75	158	97	32	48	57	137	120	100	165	135
According to motor type												P1	P
Mono, external rotor, IP 20 with cover												173	205
ATEX Three-phase												262	295
Three-phase, IP55												253	285
ONLY LG POSITION 315, 0, 90 ET 135													

Left Rotation (Counter-Clockwise) for Storm 10 with metal stand



LG 180



LG 225



LG 270



LG 315



LG 0



LG 45



LG 90



LG 135

## NOISE LEVELS

Acoustic (dB)					Frequency Octave (Hz)							
Speed (T/min)	Qv (m <sup>3</sup> /h)	Sp (Pa)	LwA dB(A)	LpA* dB(A)	63	125	250	500	1000	2000	4000	8000
1540	80	79	67	46	82	79	72	61	59	47	40	34
2870	157	308	81	61	97	94	86	76	74	62	55	49

\*Acoustic pressure Lp at 3 meters - Outlet acoustic data available on request.

# STORM SERIES - STORM 10

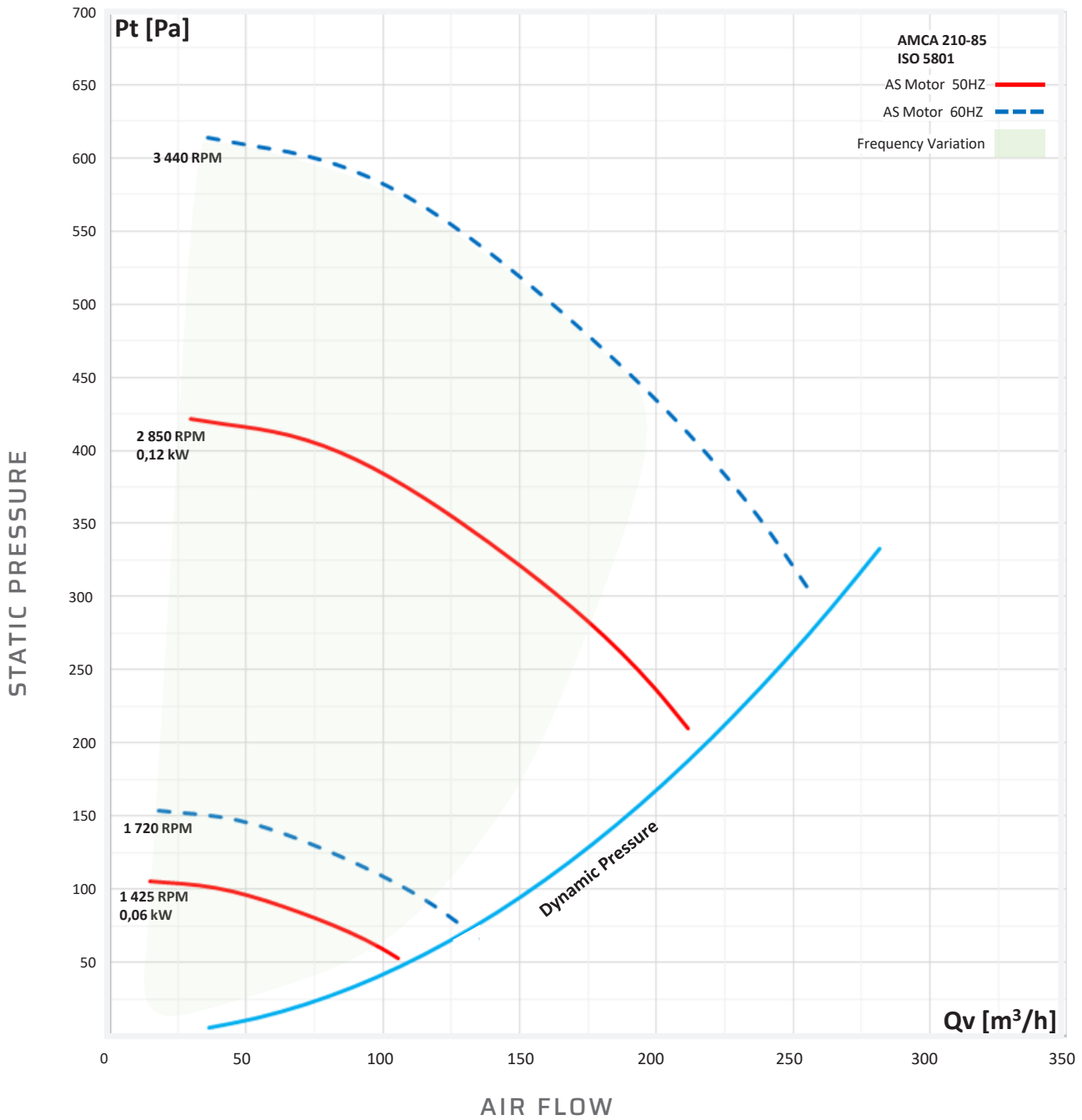

## ELECTRICAL FEATURES

Motor	Power (kW)	Motor RPM	Voltage (V)	Intensity (A)	Weight (kg)	Reference Number
IP55 Asynchronous Single-Phase	0,06 (rotor extérieur)	1200	230	0,31	2,75	61102010RE
	0,09	1450	230	0,84	4,17	61102010
	0,12	2870	230	0,95	3,8	61103010
IP55 Asynchronous Three-Phase	0,09	1450	230/400	0,79/0,45	4,17	61102000
	0,12	2870	230/400	0,63/0,36	4,17	61103000
IP55 Asynchronous Three-Phase ATEX 	0,06	1450	230/400	0,59/0,34	6	61102003
	0,09	2870	230/400	0,69/0,04	6,2	61103003

Mandatory PTC Sensor for ATEX motor with Frequency Inverter.