



VARIASEAT 400/750

0,37kW – 0,75kW

Table of contents

1. Settings list	1
2. How to modify the settings	2
3. Connecting the Power Supply	2
4. Connecting a SEAT controller	3
5. Connecting priority speeds	3
6. Connecting a manual potentiometer	4
7. Connecting a PTC sensor	4
8. Dimensions and cables	4

1. Settings list

Setting	Description	Value	Unit
Pr 00	Save (Select SAVE then press reset )	nonE	N.C.
Pr 01	Minimum Frequency	15.00	Hz
Pr 02	Maximum Frequency	55.00	Hz
Pr 03	Preset Frequency 1	30.00	Hz
Pr 04	Preset Frequency 2	40.00	Hz
Pr 05	Preset Frequency 3	55.00	Hz
Pr 06	Reversing relay 1 (Terminal 41-42)	Not inv. (Healthy)	Invert (Trip)
Pr 07	Logic input mode 5 (Terminal 14)	Input (tH if PTC)	N.C.
Pr 08	Analog input 2 Value (Terminal 5)	0.00	%
Pr 09	Acceleration ramp	10.0	s/100Hz
Pr 10	Deceleration ramp	10.0	s/100Hz
Pr 11	Analog input 1 Value (Terminal 2)	0.00	%
Pr 12	Analog input mode 1 (Terminal 2)	Volt	or 4-20mA
Pr 20	Motor Nominal Current	1.87	A
Pr 21	Nominal Speed Motor	1500 / 3000	rpm
Pr 22	Motor Nominal Voltage	230 / 400	V
Pr 23	Power Factor Nominal	0.75	N.C.
Pr 24	Reverse Select	Off	N.C.
Pr 25	Switching frequency	6	KHz



These settings are factory preset and specific to each motor. Any changes to these settings can seriously damage the motor and void the warranty.

SEAT Ventilation
70 Impasse Jean Mermoz
Parc Technologique Delta Sud
09340 Verniolle, France

2. How to modify the settings

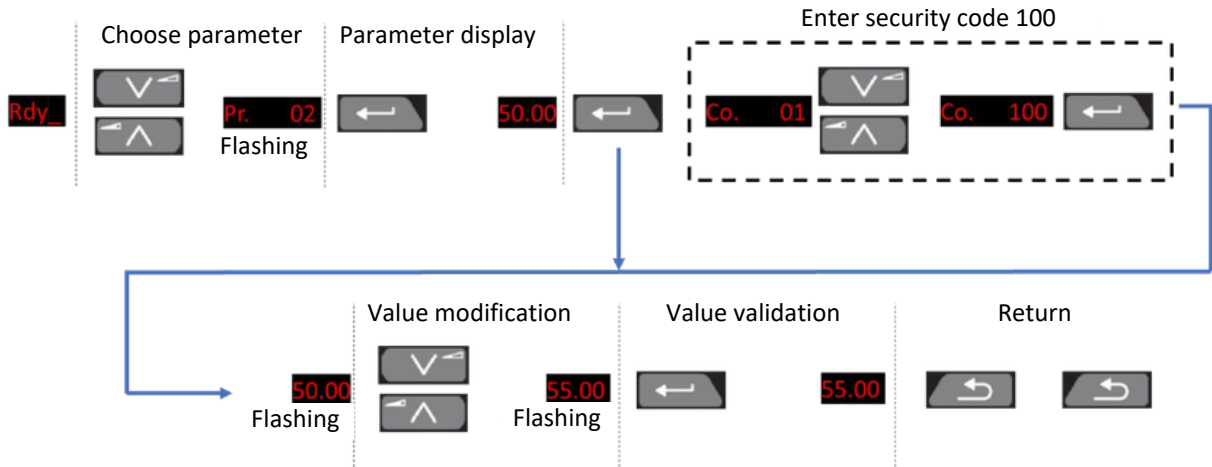

3. Connecting the Power Supply

Single phase VFD 230V

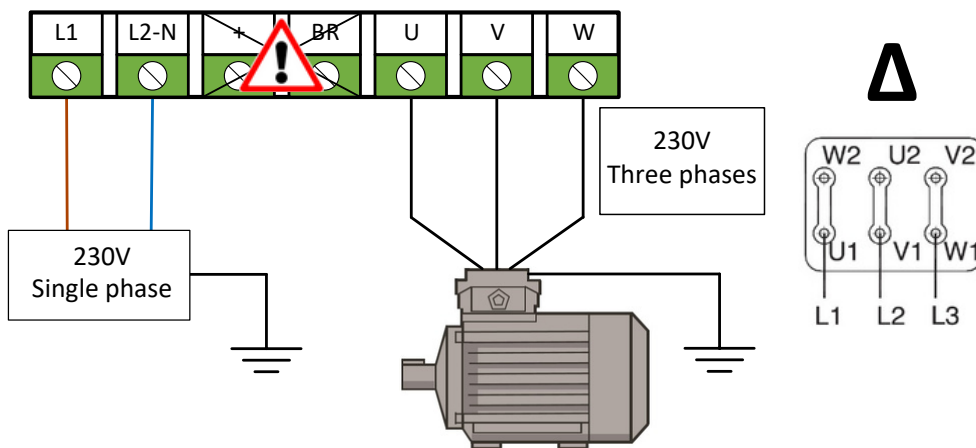

Always check voltage rating for Δ and Y connections on motor nameplate.

Three phases VFD 400V

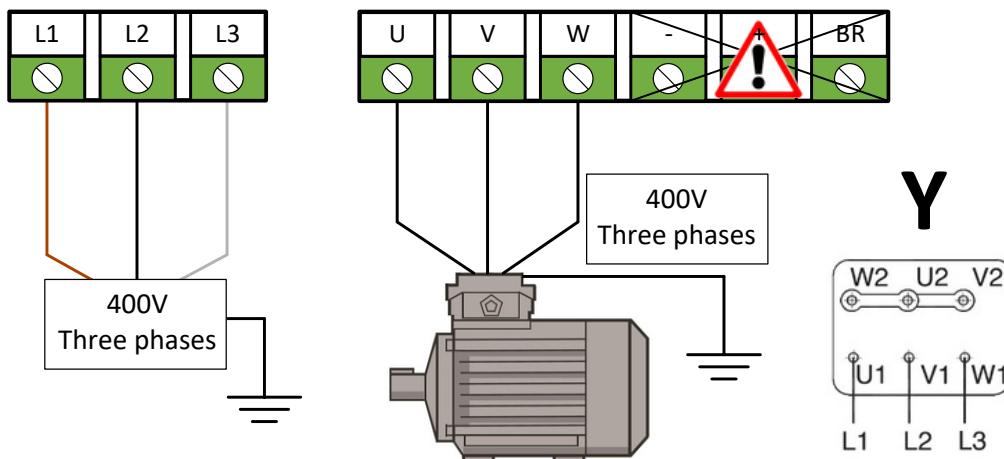



4. Connecting a SEAT controller

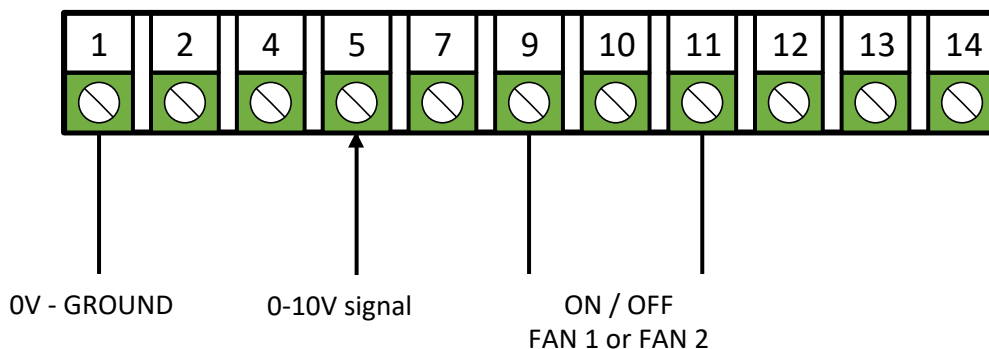

5. Connecting priority speeds

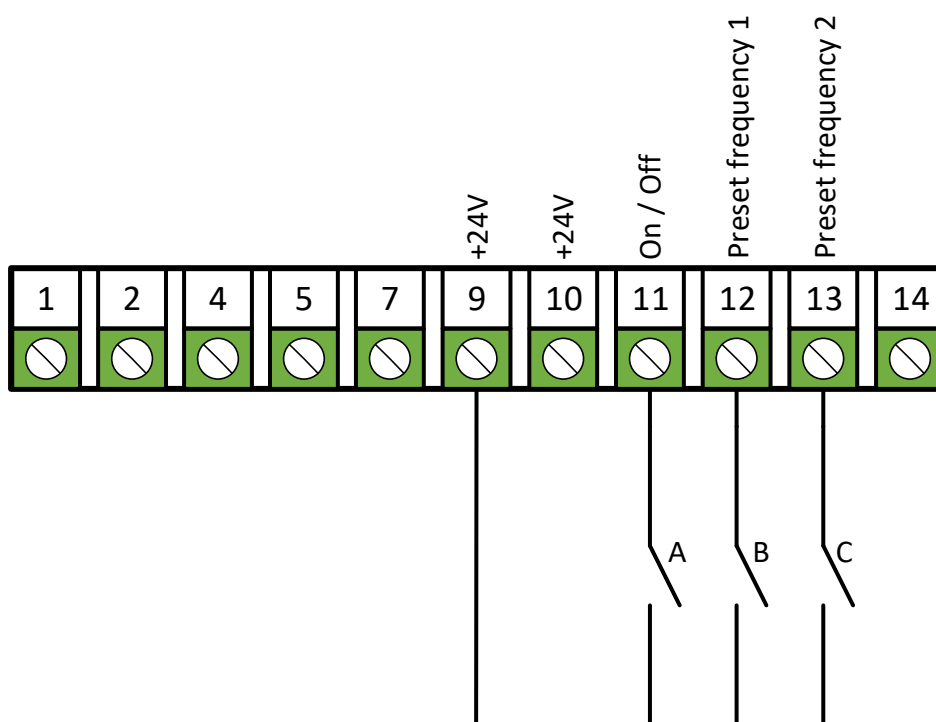

Contact A	Contact B	Contact C	Results
0	0	0	The frequency inverter is stopped and displays "rdy"
1	0	0	The frequency inverter is running and operates at the minimum frequency (Pr 01 = 15Hz)
1	1	0	Preset frequency 1 is activated (Pr 03 = 30 Hz)
1	0	1	Preset frequency 2 is activated (Pr 04 = 40 Hz)
1	1	1	Preset frequency 3 is activated (Pr 05 = 50 Hz)

Contact A between terminals 9 and 11 is required to run the drive.

Priority speed 1 is activated with contact B.

Priority speed 2 is activated with contact C.

Priority speed 3 is activated by operating both contact B and C.

6. Connecting a manual potentiometer

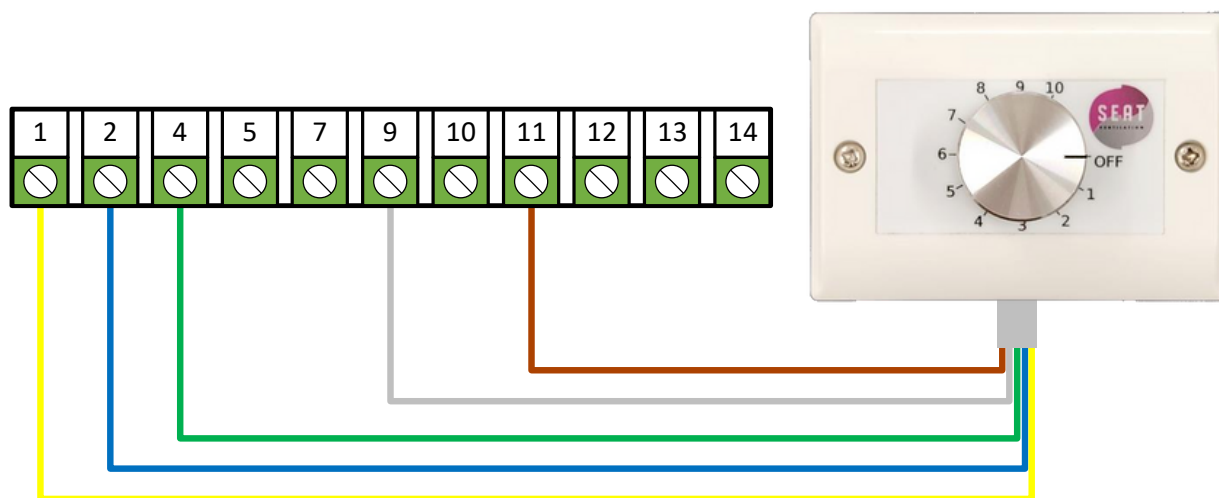

7. Connecting a PTC sensor

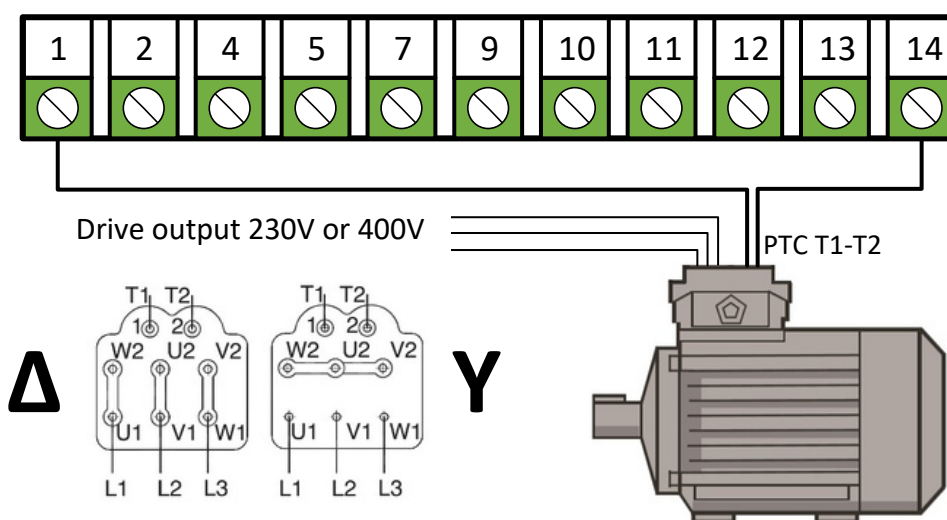

8. Dimensions and cables

Drive	Height		Width		Depth		Fuse rating A	Cable size Input		Cable size Output	
	mm	in	mm	in	mm	in		mm ²	AWG	mm ²	AWG
0,37kW 1Ph	160	6.30	75	2.95	130	5.12	6	1 - 2.5	16 - 12	1 - 2.5	16 - 12
0,75kW 1Ph	160	6.30	75	2.95	130	5.12	16	1 - 2.5	16 - 12	1 - 2.5	16 - 12
0,37kW 3Ph	205	8.07	78	3.07	150	5.91	6	1 - 4	16 - 10	1 - 4	16 - 10
0,75kW 3Ph	205	8.07	78	3.07	150	5.91	6	1 - 4	16 - 10	1 - 4	16 - 10

The use of a shielded cable is recommended between drive and motor, the shield must be connected to earth using the grounding bracket/clamp.