

# REGULATION SOLUTIONS FOR AIR EXTRACTION IN LABORATORIES



SECURITY

SIMPLICITY

ENERGY SAVINGS

CLIENT CARE & TRAINING

A complete range of solutions  
to guarantee the security  
of your laboratory



«An experienced team that listens to clients worldwide.»



## THE COMPANY

**SEAT Ventilation is the French leader and one of the world's leading manufacturers of extraction systems for corrosive or toxic gases or vapours.**

Endowed with high performance levels, SEAT Ventilation is employed in different areas, including laboratories, chemical and petrochemical industries, water treatments, swimming pools, food industries, electronics, hospitals, universities, surface treatments, etc. Anti-corrosion polypropylene ventilation fans are installed in the centre of a toxic and corrosive working area where stainless metallic materials are more resistant.

Distributed in 80 countries world-wide, SEAT products are recognised by their design, code colour and reliability.

SEAT ventilation offers solutions to control, maintain and regulate laboratory ventilation and airflow. L.SOLUTION is a concept that allows operators to adapt their extraction system to better suit their requirements, offer better laboratory management and further protect personnel from potential dangers. Our controllers are compliant with standard EN 14175 and when used in an extraction system can reduce energy consumption by up to 60%.

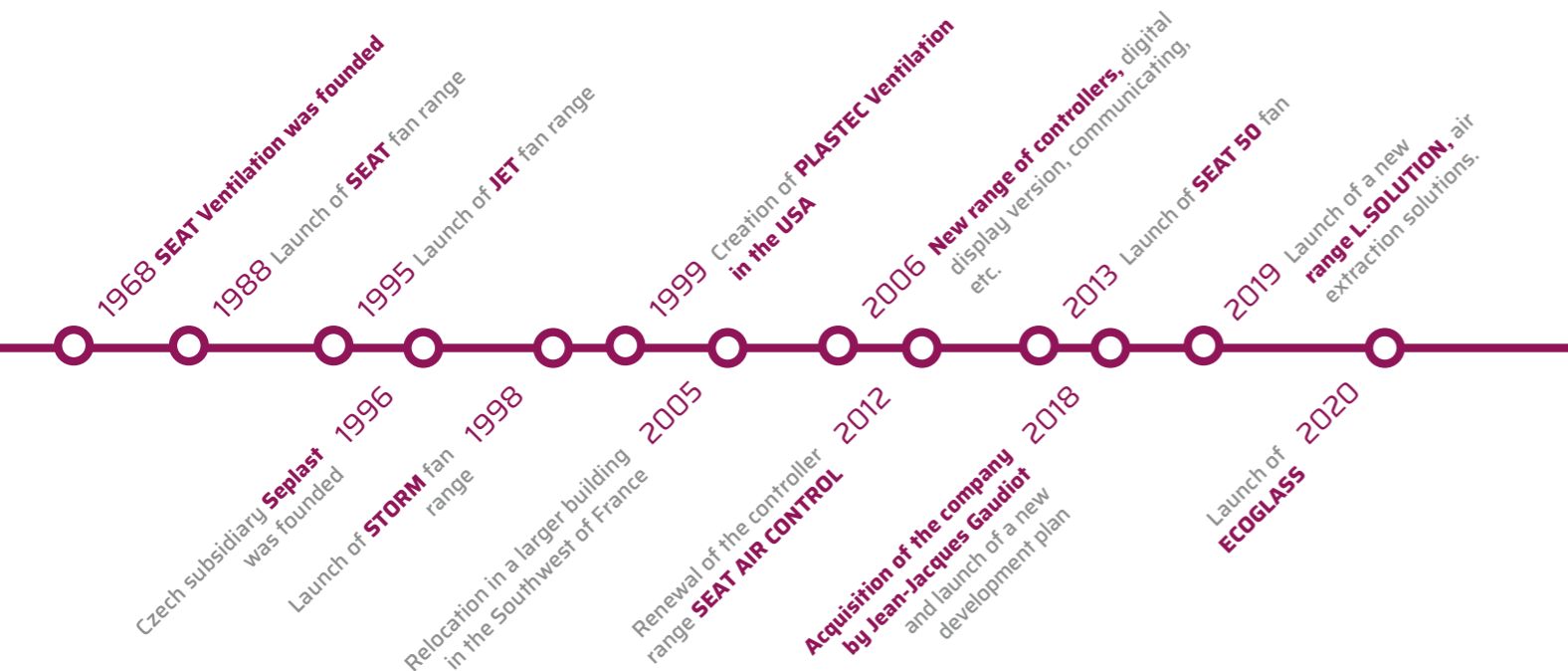

## OVERVIEW



06/11 REMOTE HMI CONTROLLER



12/19 FULLY INTEGRATED CONTROLLER



20/25 MODULAR CONTROLLER



26/27 SAFETY OR STORAGE CABINET CONTROLLER



28/29 ECOGLASS



30/31 ACCESSORIES

32/37 EXAMPLES OF INSTALLATIONS

38 THE COMPANY

The information contained within this catalogue is for general guidance only. Additional advice on application specific integrations can be supplied by our technical team. Please contact us with the details of your application. The information within this catalogue may be subject to error and therefore we reserve the right to make changes to technical data or product ranges without warning.

# A COMPLETE RANGE FOR THE REGULATION OF YOUR AIR EXTRACTION SYSTEM

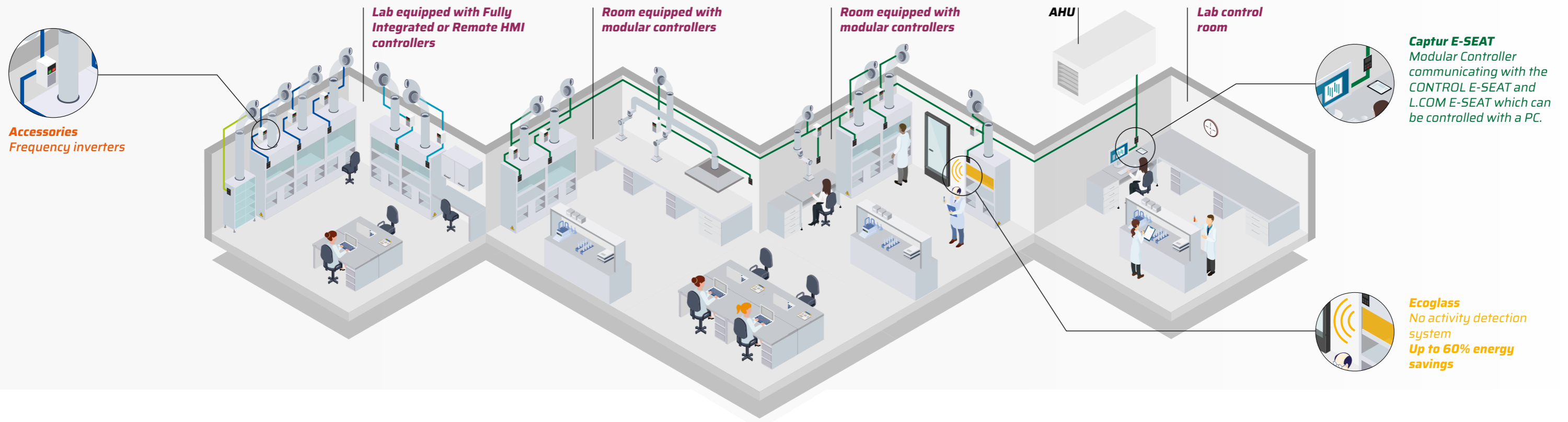

## OUR CONTROLLERS

References	EN14175 Standard	Mounting positions				Audible and visual alarms	Sash overrun indication	Speed probe	Pressure switch	Linear position sensor	0-10 V output	4-20mA or 0-10V output	Ventilation relays	Light relays	Alarm relays	Back-up battery	Number of regulation mode	Auxiliary inputs	Configurable output	MODBUS communication	RJ45 Ethernet	Supervision	HMI Dimensions W x H x L
		Vertical	Horizontal	Vertical + Display	Horizontal + Display																		
<b>Type A remote HMI</b>	819750/819751	✓	✓	✓	✓	✓	✓	✓	✗	✗	✗	✗	2	✓	✓	✓	1	1	✗	✗	✗	✗	130 x 40 x 24
<b>Type C remote HMI</b>	819753/819754	✓	✓	✓	✓	✓	✓	✓	✗	✗	✓	✗	2	✓	✓	✓	1	1	✗	✗	✗	✗	130 x 40 x 24
<b>Type C two speeds remote HMI</b>	819756/819757	✓	✓	✓	✓	✓	✓	✓	✗	✗	✓	✗	2	✓	✓	✓	1	1	✗	✗	✗	✗	130 x 40 x 24
<b>Type A fully integrated</b>	819700/819701	✓	✓	✓	✓	✓	✓	✓	✗	✗	✗	✗	2	✓	✓	✓	1	1	✗	✗	✗	✗	210 x 75 x 34
<b>Type C fully integrated</b>	819703/819704	✓	✓	✓	✓	✓	✓	✓	✗	✗	✓	✗	2	✓	✓	✓	1	1	✗	✗	✗	✗	210 x 75 x 34
<b>Type C two speeds fully integrated</b>	819706	✓	✓	✓	✓	✓	✓	✓	✗	✗	✓	✗	2	✓	✓	✓	1	1	✗	✗	✗	✗	210 x 75 x 34
<b>CONTROL SEAT</b>	819730	✓	✗	✗	✓	✓	✓	✓	✗	✓	✓	✓	2	✓	✓	✓	10	4	3	✗	✗	✗	115 x 65 x 18
<b>CONTROL E-SEAT</b>	819732	✓	✗	✗	✓	✓	✓	✓	✗	✓	✓	✓	2	✓	✓	✓	10	4	3	✓	✗	✗	115 x 65 x 18
<b>L.COM E-SEAT</b>	819733	✓	✗	✗	✓	✓	✗	✗	✓	✗	✓	✓	2	✓	✓	✓	3	4	3	✓	✗	✗	115 x 65 x 18
<b>CAPTUR E-SEAT</b>	819736	✓	✗	✗	✓	✓	✓	✗	✗	✗	✓	✓	2	✓	✓	✓	1	4	3	✓	✓	✓	115 x 65 x 18
<b>Storage controller</b>	819696	✗	✓	✓	✗	✓	✗	✓	✗	✗	✗	✗	1	✓	✓	✓	1	1	✗	✗	✗	✗	210 x 75 x 34
<b>Cabinet controller</b>	819697	✗	✗	✗	✓	✓	✗	✓	✗	✗	✗	✗	1	✓	✓	✓	1	1	✗	✗	✗	✗	210 x 75 x 34

✓ Available    ✓ Available on request    ✗ Unavailable

# REMOTE HMI CONTROLLER TYPE A

REF 819750  
REF 819751 (display option)

The TYPE A remote HMI controller is a security device which monitors the fan from a lab fume hood.

A speed sensor measures the face velocity. In addition, it informs the user with visual and audible alarms in case of malfunctions. On-site adjustments are possible.



## ADVANTAGES

Suitable for all types of fume hood

- No maintenance
- Easy to use and install
- Reliable
- HMI monitors take up minimum space on the fume hoods and control the exhaust fan. The settings can be carried out in the lab.
- Visual and audible alarms
- Pre-caliber to 0.5 m/s
- Compliant with EN 14175

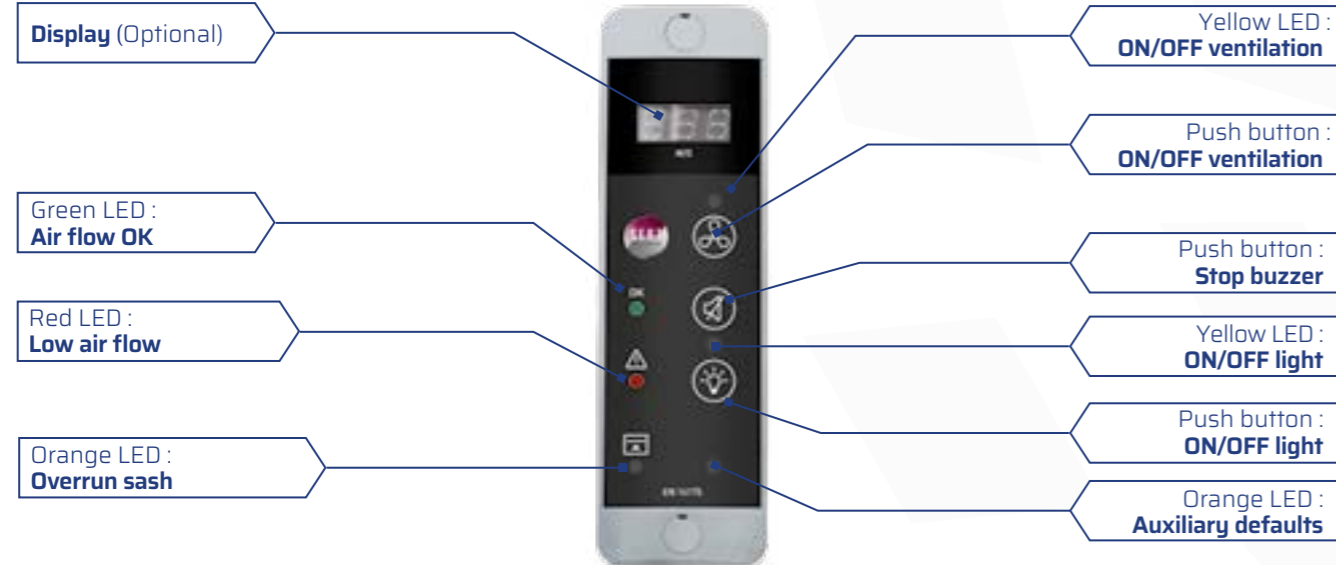

✓ This controller is EN 14175 and RoHS compliant

HMI Dimensions  
130x40x24

CPU Dimensions  
241x182x65

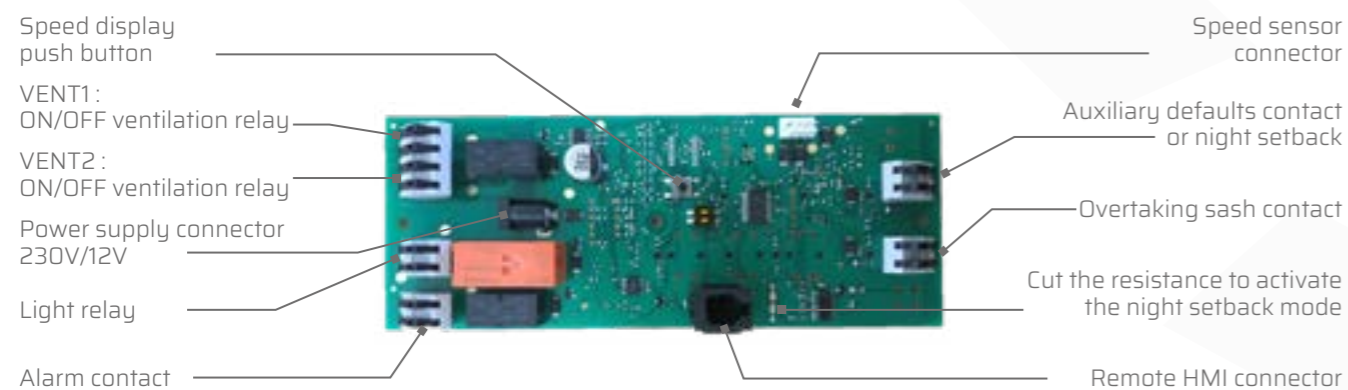

## DIAGRAM

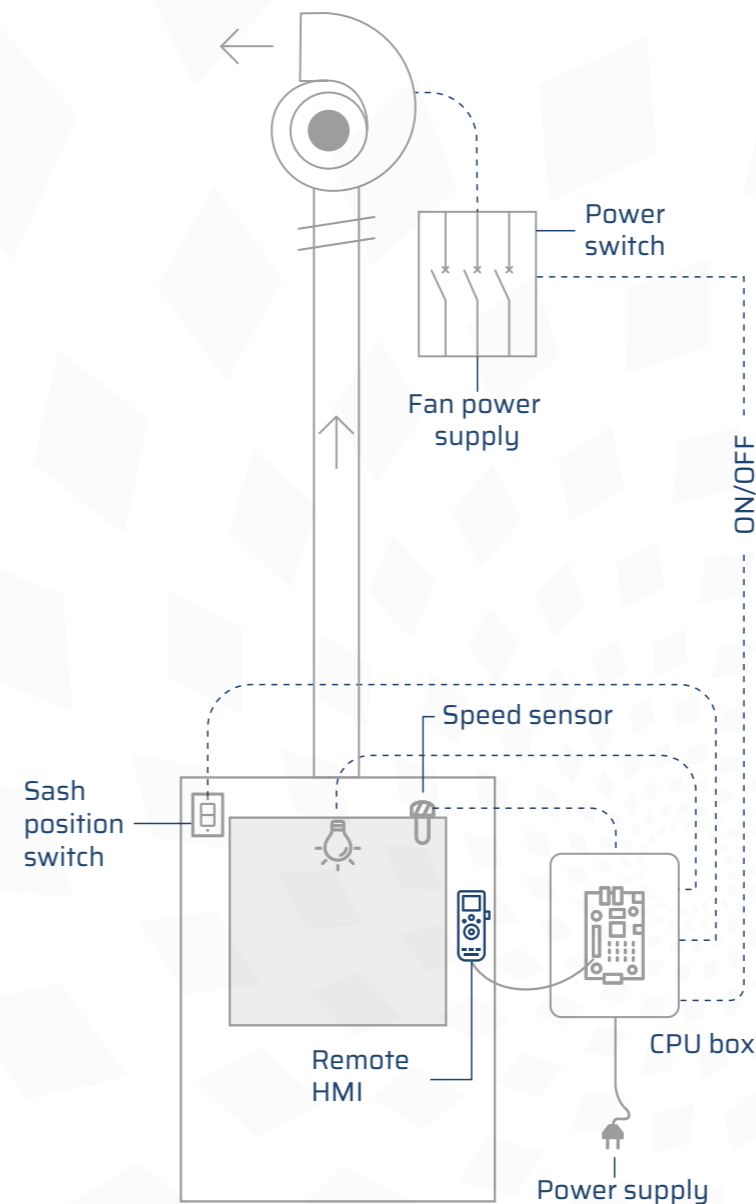

## OPERATING PRINCIPLE

The TYPE A remote HMI controller is used to control the ventilation of a fixed airflow fume hood.

Three push buttons are used to control the ventilation, the lighting and to stop the alarm.

Pressing the ON/OFF ventilation button on the HMI controls a fan and/or a motorised damper via the two relays VENT 1 and VENT 2.

The sensor measures the front speed and the controller informs the user by means of several indicators.

The green LED is lit when the face velocity is sufficient.

The red LED flashes when the face velocity is insufficient.

The orange «sash overrun» LED lights up if the sash is raised above the maximum safe working opening. This fault is triggered by a position switch.

The orange LED «auxiliary faults» lights up if the auxiliary input is activated.

If a failure remains within a period of time of 15-30s, the audible alarm will activate. Having identified the problem, the laboratory personnel can stop the alarm by pushing the stop buzzer button.

Pressing the light ON/OFF button controls the lighting via a 250V 16A relay.

The controller is supplied with a 230V/12V power adaptor.

The controller is factory preset to 0.5m/s and can be reset on site using an anemometer.



## OPTIONS

- Available in vertical or horizontal version
- Available in digital display version (m/s)
- Battery
- Alarm relay
- Temperature sensor
- Night setback
- Speed sensor with 5 metres wire

# REMOTE HMI CONTROLLER TYPE C

REF 819753  
REF 819754 (display option)

## The TYPE C remote HMI controller is a safety device for controlling the ventilation of a fume hood using a PID controller.

It adjusts the ventilation to maintain the set speed regardless of the height of the glass. It informs the user with visual and audible alarms if a malfunction occurs. The remote HMI enables adjustments on site and controls the fume hood ventilation.



### ADVANTAGES

#### Suitable to all types of fume hood

- PID controller
- No maintenance
- Easy to use, install and maintain
- Very high reliability
- Remote HMI with small dimensions to control the fume hood ventilation and to make adjustments on site.
- Energy savings: reduction of exhaust air by regulation
- Flexibility: the fan can be set to any speed
- Comfortable to use: low air speeds ensure low noise levels
- Pre-caliber to 0.5 m/s
- Compliant with EN 14175

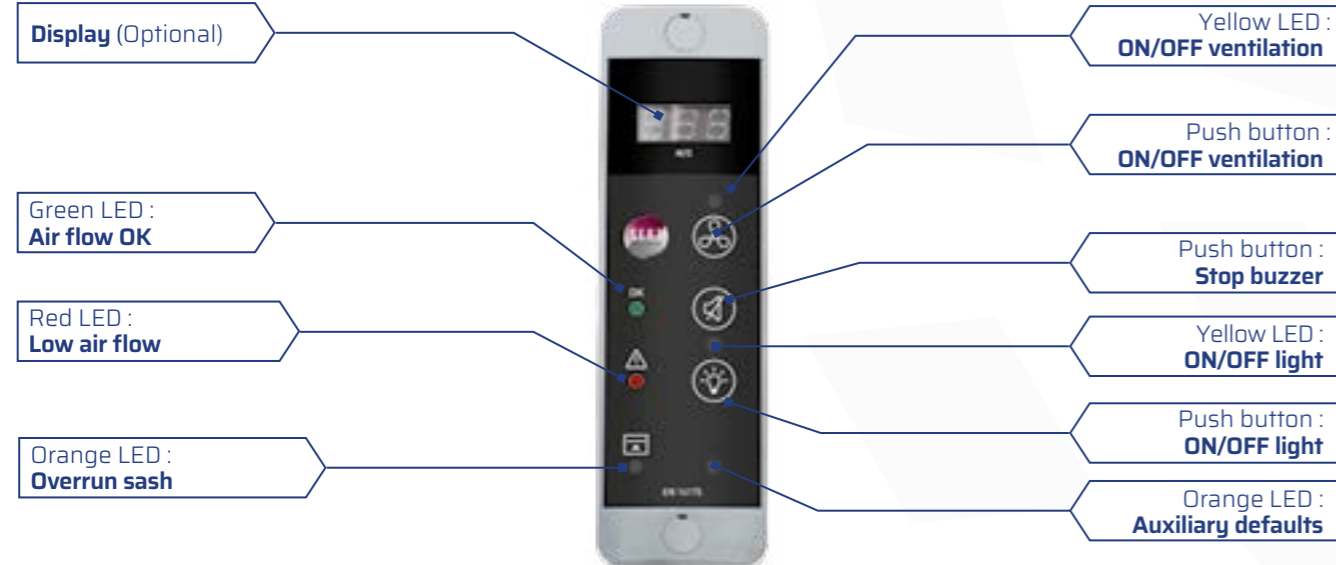

✓ This controller is EN 14175 and RoHS compliant

HMI Dimensions  
130x40x24

CPU Dimensions  
241x182x65

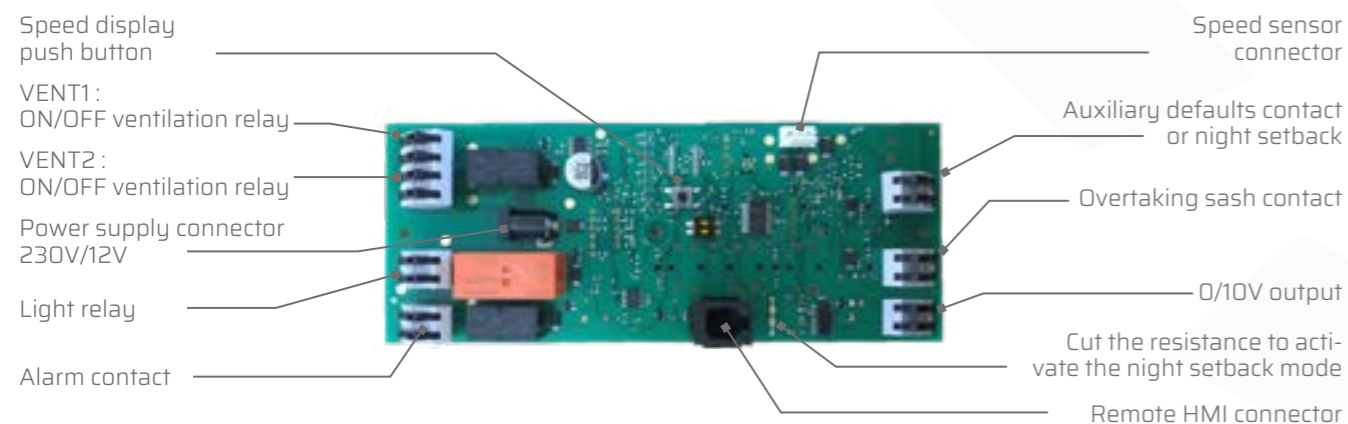

## DIAGRAM

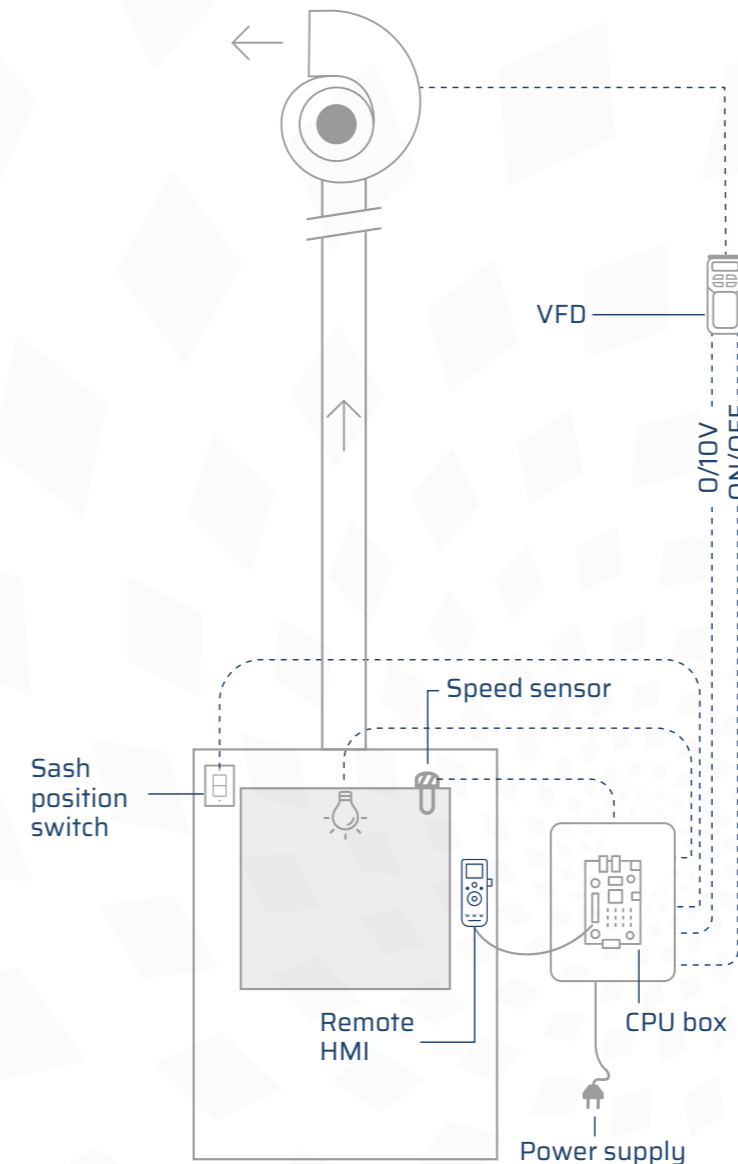

## OPTIONS

- Available in vertical or horizontal version
- Available in digital display version (m/s)
- Battery
- Alarm relay
- Temperature sensor
- Night setback
- Speed sensor with 5 metres wire

## OPERATING PRINCIPLE

The Type C remote HMI airflow controller is used to control the airflow of a fume hood.

Three push buttons are used to control the ventilation, the lighting and to stop the alarm.

Pressing the ON/OFF ventilation button on the HMI controls a fan and/or a motorised damper via the two relays VENT1 and VENT2.

The sensor measures the face velocity, and the controller modulates the 0/10V signal with a PID controller to maintain the speed setpoint regardless of the window height. This analogue signal is sent to the VFD or motorised damper to modify the flow rate.

The green LED is lit when the face velocity is sufficient.

The red LED flashes when the face velocity is insufficient.

The orange «sash overrun» LED lights up if the sash is raised above the maximum safe working opening. This fault is triggered by a position switch.

The orange LED «auxiliary faults» lights up if the auxiliary input is activated.

If a failure remains within a period of time of 15-30s, the audible alarm will activate. Having identified the problem, the laboratory personnel can stop the alarm by pushing the stop buzzer button.

Pressing the light ON/OFF button controls the lighting via a 250V 16A relay.

The controller is supplied with a 230V/12V power adaptor.

The controller is factory preset to 0.5m/s and can be reset on site using an anemometer.

# REMOTE HMI CONTROLLER TYPE C 2-SPEED

REF 819756  
REF 819757 (display option)

The TYPE C 2-speed remote HMI controller is a safety device that regulates the airflow according to a low and high speed depending on the sash position.

The controller engages the second speed by means of a switch placed on the sash path.

It informs the user with visual and audible alarms if a malfunction occurs.

The remote HMI enables adjustments on site and controls the fume hood ventilation.



## ADVANTAGES

Suitable to all types of fume hood

- Immediate change in flow rate
- High stability of the extracted flow rate
- Noise reduction
- Energy savings
- No maintenance
- Easy to use
- Very high reliability
- EN 14175 compliance

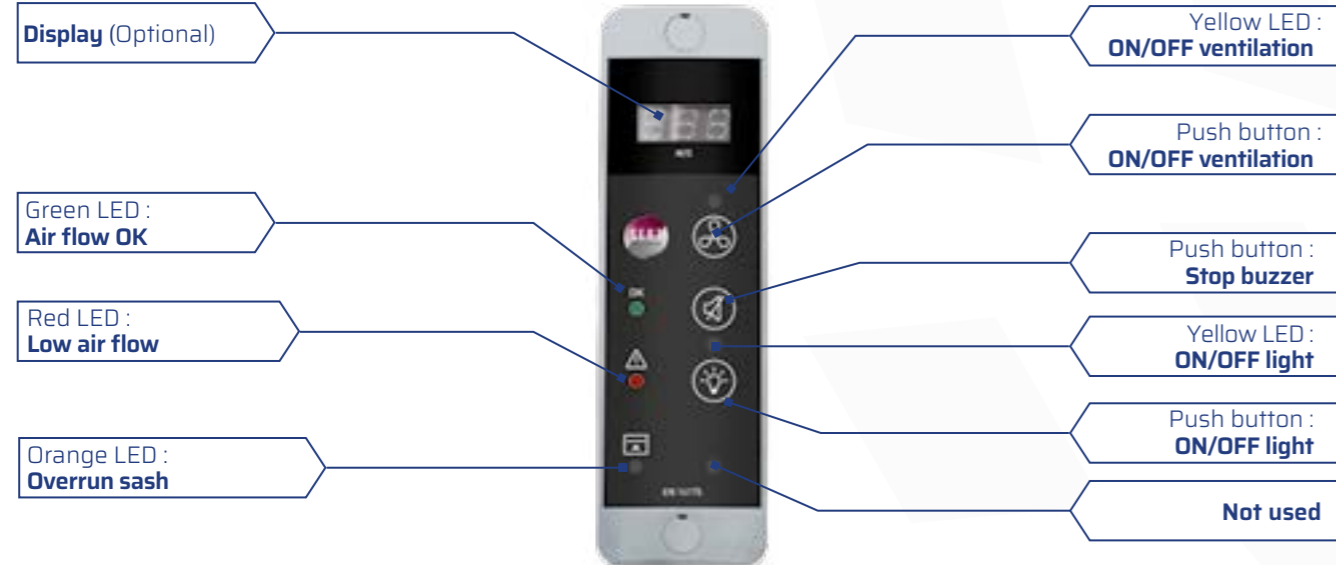

✓ This controller is EN 14175 and RoHS compliant

HMI Dimensions  
130x40x24

CPU Dimensions  
241x182x65

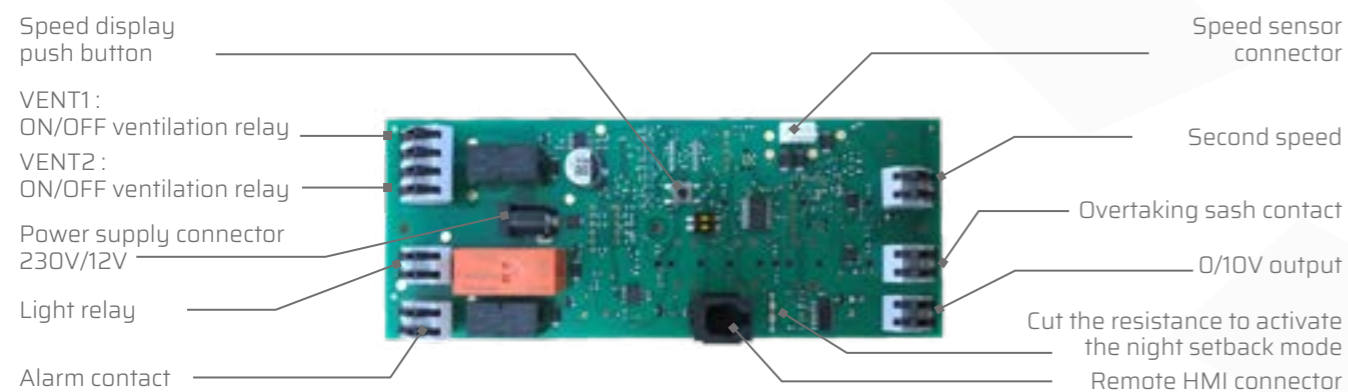

## DIAGRAM

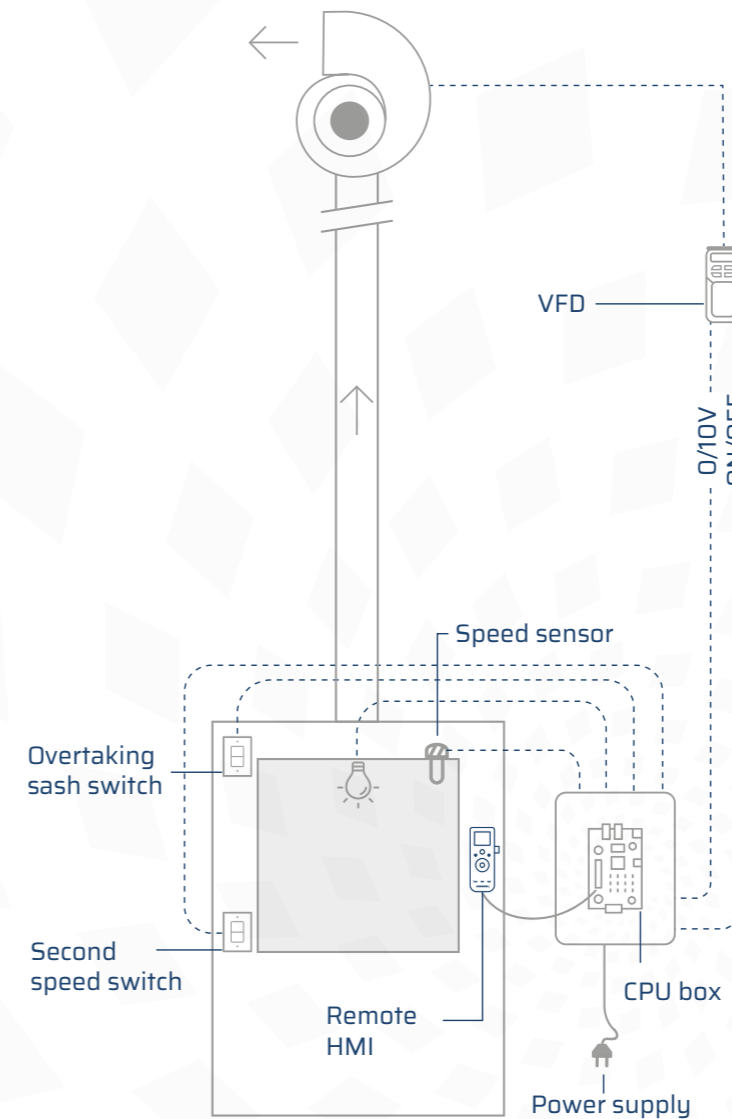

## OPTIONS

- Available in vertical or horizontal version
- Available in digital display version (m/s)
- Battery
- Alarm relay
- Temperature sensor
- Night setback
- Speed sensor with 5 metres wire

## OPERATING PRINCIPLE

The TYPE C 2-speed remote HMI flow controller controls the airflow of a fume hood.

Three push buttons are used to control the ventilation, the lighting and to stop the alarm.

Pressing the ON/OFF ventilation button on the HMI controls a fan and/or a motorised damper via the two relays VENT1 and VENT2.

It allows to regulate the ventilation according to 2 operating points determined by the position of the sash.

- In the low position, the controller sends a first fixed voltage.
- In high position, the controller sends a second fixed voltage.

The switch allows to alternate from one speed to another. The controller ensures both the safety of the operator and an important energy saving.

The green LED is lit when the face velocity is sufficient.

The red LED flashes when the face velocity is insufficient.

The orange «sash overrun» LED lights up if the sash is raised above the maximum safe working opening. This fault is triggered by a position switch.

The orange LED «auxiliary faults» lights up if the auxiliary input is activated.

If a failure remains within a period of time of 15-30s, the audible alarm will activate. Having identified the problem, the laboratory personnel can stop the alarm by pushing the stop buzzer button.

Pressing the light ON/OFF button controls the lighting via a 250V 16A relay.

The controller is supplied with a 230V/12V power adaptor.

The controller is factory preset to 0.5m/s and can be reset on site using an anemometer.

# FULLY INTEGRATED CONTROLLER TYPE A

REF 819700  
REF 819701 (display option)

**The TYPE A controller is a security device which monitors the fan from a lab fume hood.**

A speed sensor measures the face velocity. It informs the user with visual and audible alarms if a malfunction occurs. On-site adjustments are possible.



## ADVANTAGES

- No maintenance
- Easy to use, install and maintain
- Very high reliability
- Visual and audible alarm
- EN 14175 compliant

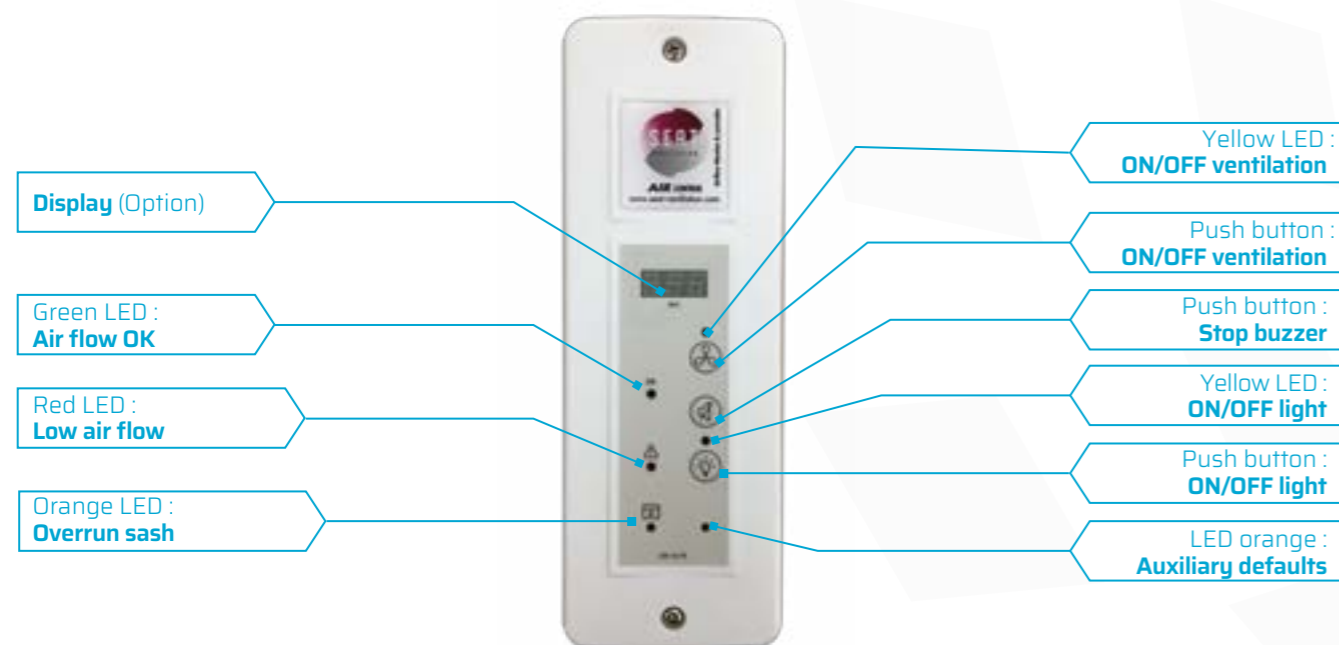

✓ This controller is EN 14175 and RoHS compliant

HMI Dimensions  
210x75x34

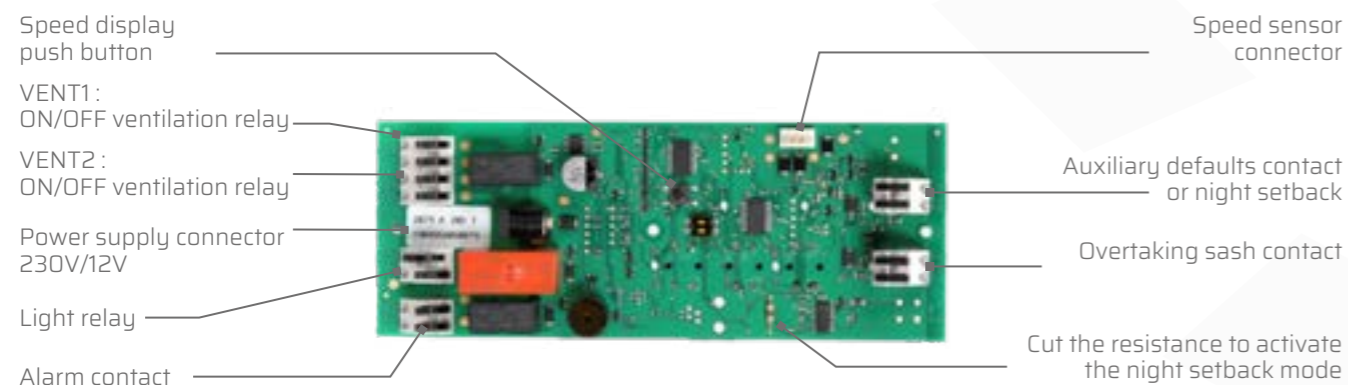

## DIAGRAM

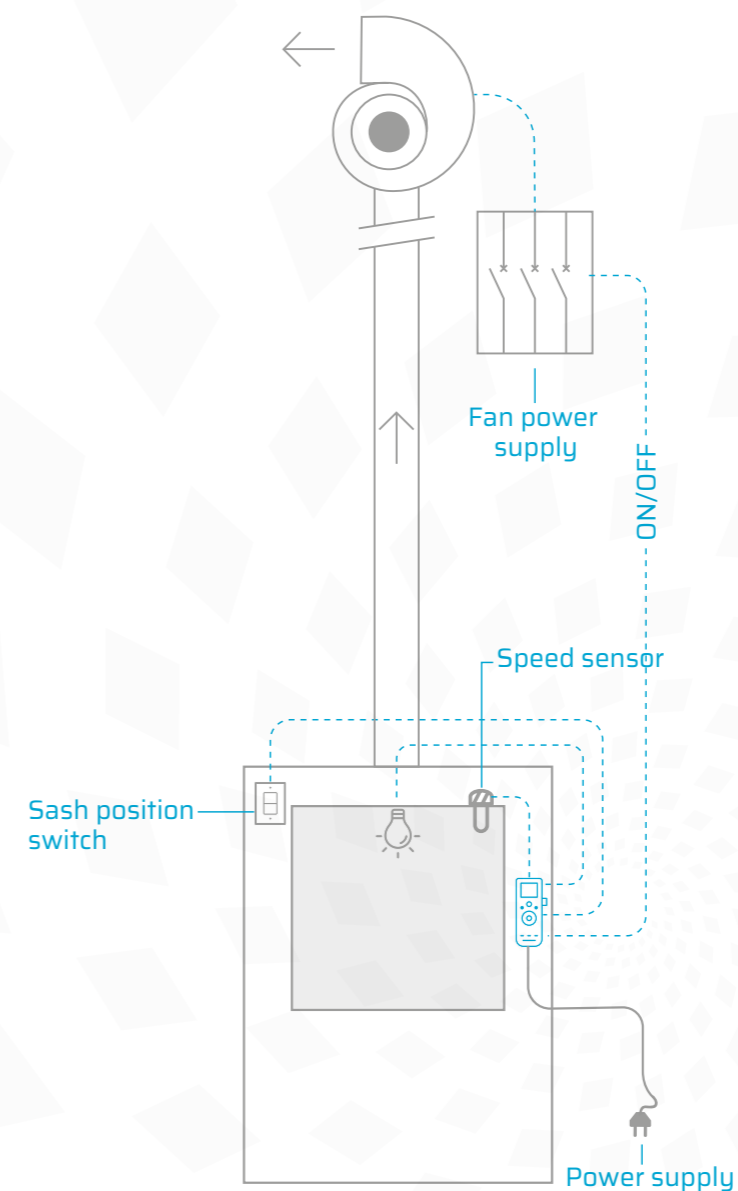

## OPERATING PRINCIPLE

**The TYPE A controller is used to control the ventilation of a fixed airflow fume hood.**

Three push buttons are used to control the ventilation, the lighting and to stop the alarm.

Pressing the ON/OFF ventilation button on the HMI controls a fan and/or a motorised damper via the two relays VENT 1 and VENT 2.

The sensor measures the front speed and the controller informs the user by means of several indicators.

The green LED is lit when the face velocity is sufficient.

The red LED flashes when the face velocity is insufficient.

The orange «sash overrun» LED lights up if the sash is raised above the maximum safe working opening. This fault is triggered by a position switch.

The orange LED «auxiliary faults» lights up if the auxiliary input is activated.

If a failure remains within a period of time of 15-30s, the audible alarm will activate. Having identified the problem, the laboratory personnel can stop the alarm by pushing the stop buzzer button.

Pressing the light ON/OFF button controls the lighting via a 250V 16A relay.

The controller is supplied with a 230V/12V power adaptor.

The controller is factory preset to 0.5m/s and can be reset on site using an anemometer.



## OPTIONS

- Available in vertical or horizontal version
- Available in digital display version (m/s)
- Battery
- Alarm relay
- Temperature sensor
- Night setback
- Speed sensor with 5 metres wire

# FULLY INTEGRATED CONTROLLER TYPE C

REF 819703  
REF 819704 (display option)

## The TYPE C controller is a safety device for controlling the ventilation of a fume hood using a PID controller.

It adjusts the ventilation to maintain the set speed regardless of the height of the glass. It informs the user with visual and audible alarms if a malfunction occurs. The remote HMI enables adjustments on site and controls the fume hood ventilation.



### ADVANTAGES

- PID controller
- No maintenance
- Easy to use, install and maintain
- Very high reliability
- Energy savings: reduction of exhaust air by regulation
- Flexibility: the fan can be set to any speed
- Comfortable to use: low air speeds ensure low noise levels
- Visual and audible alarm
- Pre-caliber to 0.5m/s
- EN 14175 compliant

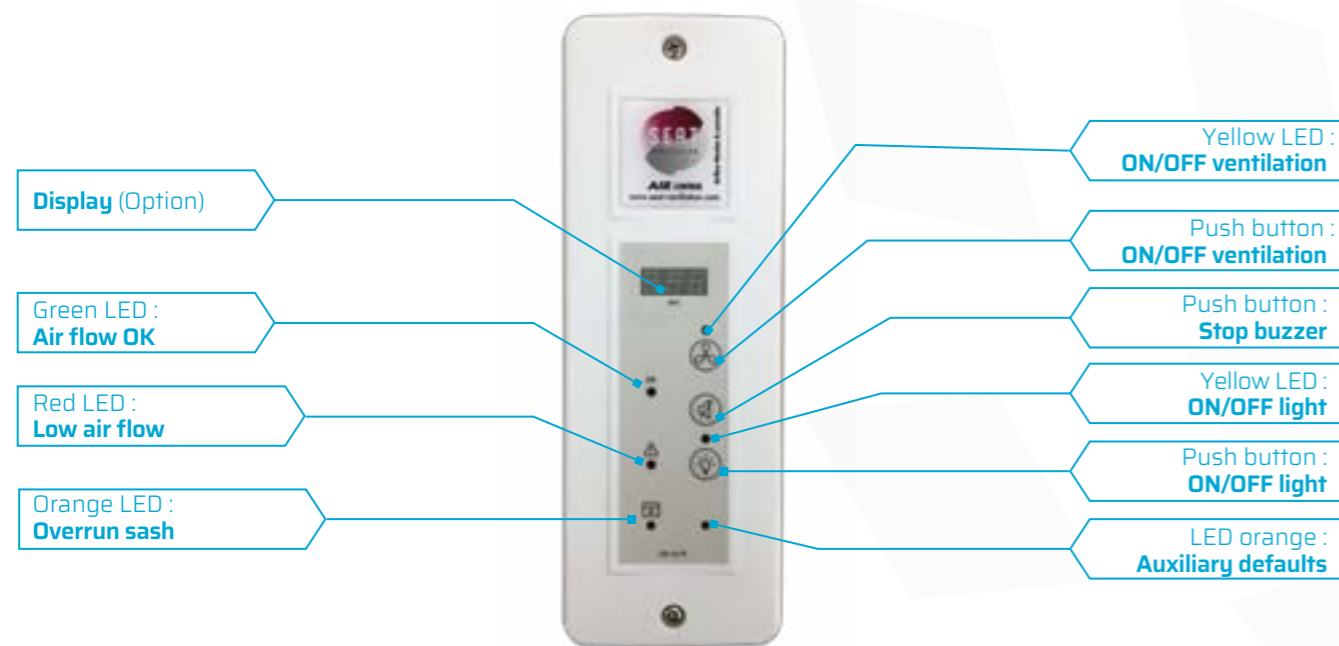

✓ This controller is EN 14175 and RoHS compliant

HMI Dimensions  
210x75x34

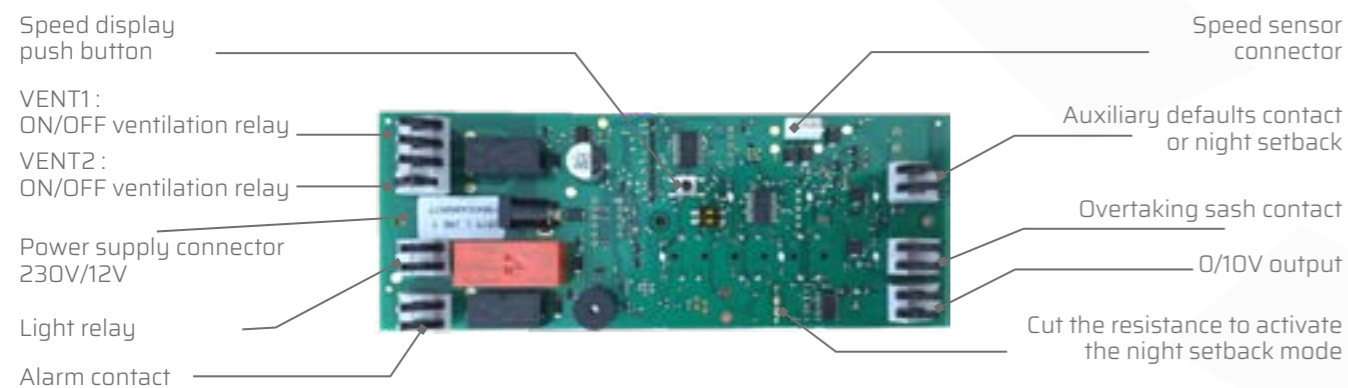

## DIAGRAM

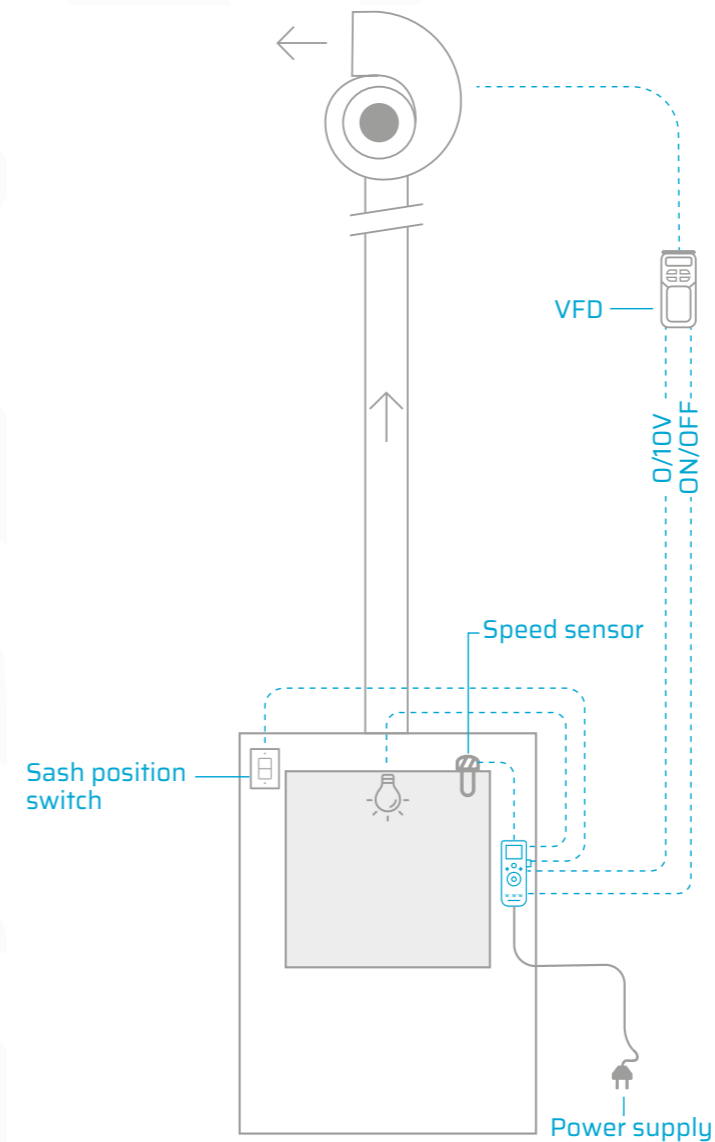

### OPTIONS

- Available in vertical or horizontal version
- Available in digital display version (m/s)
- Battery
- Alarm relay
- Temperature sensor
- Night setback
- Speed sensor with 5 metres wire

## OPERATING PRINCIPLE

The Type C airflow controller is used to control the airflow of a fume hood.

Three push buttons are used to control the ventilation, the lighting and to stop the alarm.

Pressing the ON/OFF ventilation button on the HMI controls a fan and/or a motorised damper via the two relays VENT1 and VENT2.

The sensor measures the face velocity, and the controller modulates the 0/10V signal with a PID controller to maintain the speed setpoint regardless of the window height. This analogue signal is sent to the VFD or motorised damper to modify the flow rate.

The green LED is lit when the face velocity is sufficient.

The red LED flashes when the face velocity is insufficient.

The orange «sash overrun» LED lights up if the sash is raised above the maximum safe working opening. This fault is triggered by a position switch.

The orange LED «auxiliary faults» lights up if the auxiliary input is activated.

If a failure remains within a period of time of 15-30s, the audible alarm will activate. Having identified the problem, the laboratory personnel can stop the alarm by pushing the stop buzzer button.

Pressing the light ON/OFF button controls the lighting via a 250V 16A relay.

The controller is supplied with a 230V/12V power adaptor.

The controller is factory preset to 0.5m/s and can be reset on site using an anemometer.



# FULLY INTEGRATED CONTROLLER TYPE C 2-SPEED

REF 819706  
REF 819707 (display option)

The TYPE C 2-speed controller is a safety device that regulates the airflow according to a low and high speed depending on the sash position.

The controller engages the second speed by means of a switch placed on the sash path.

It informs the user with visual and audible alarms if a malfunction occurs. The remote HMI enables adjustments on site and controls the fume hood ventilation.



## ADVANTAGES

- Immediate change in flow rate
- High stability of the extracted flow rate
- Energy saving
- Comfortable to use: low air speeds ensure low noise levels
- No maintenance
- Easy to use
- Very high reliability
- EN 14175 compliant

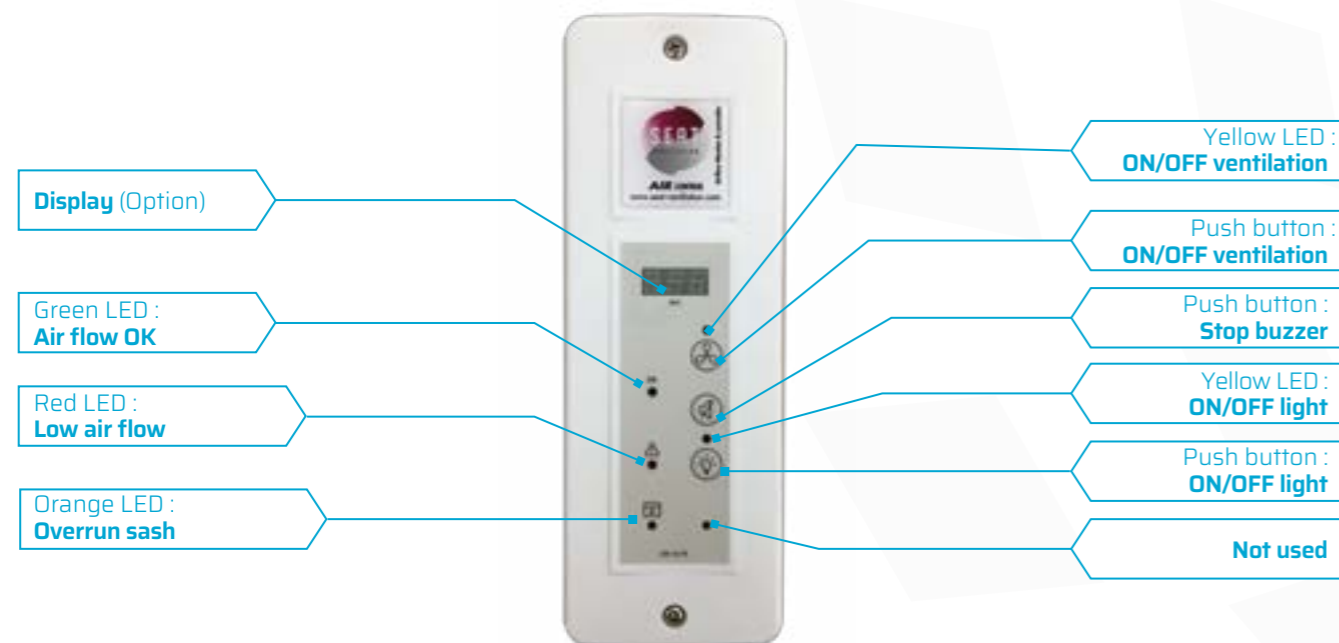

✓ This controller is EN 14175 and RoHS compliant

HMI Dimensions  
210x75x34

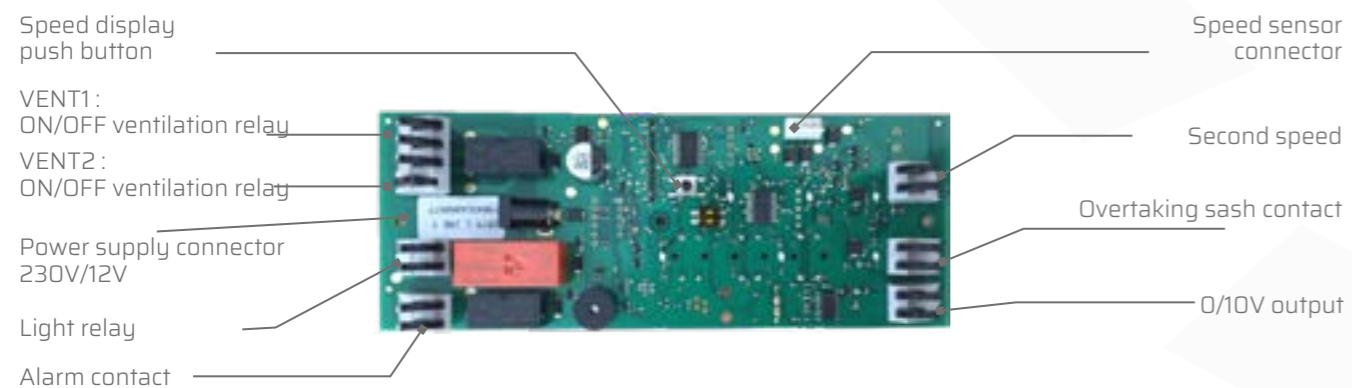

## DIAGRAM

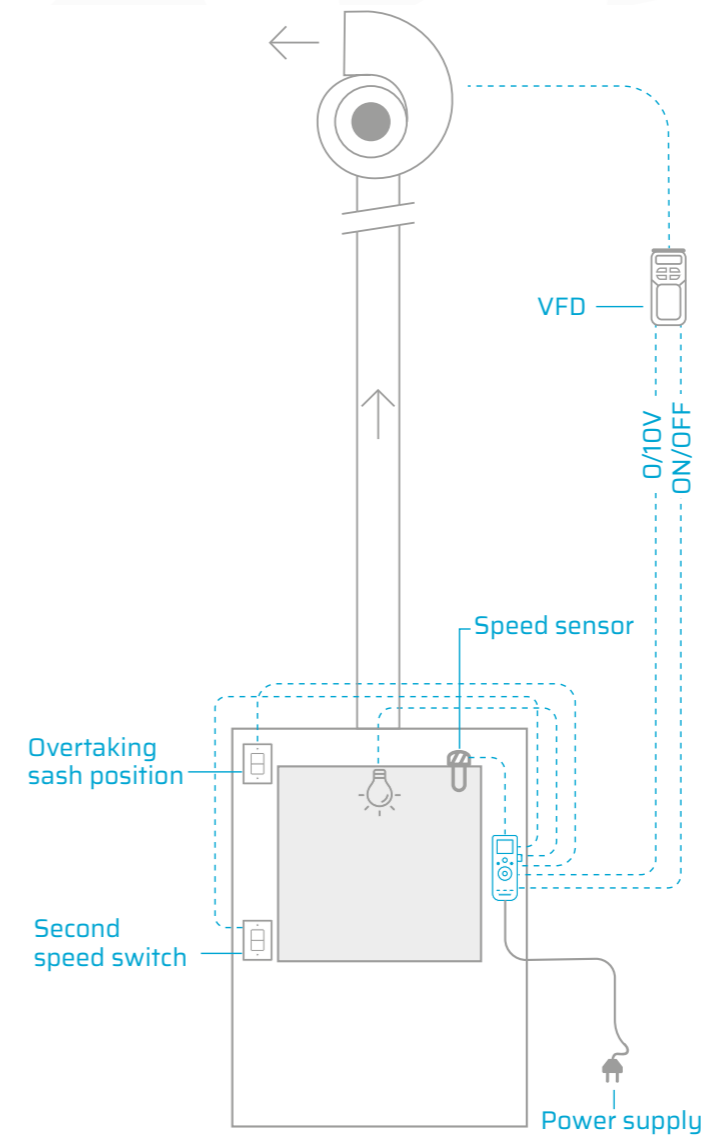

## OPTIONS

- Available in vertical or horizontal version
- Available in digital display version (m/s)
- Battery
- Alarm relay
- Temperature sensor
- Night setback
- Speed sensor with 5 metres wire

## OPERATING PRINCIPLE

The TYPE C 2-speed flow controller controls the airflow of a fume hood.

Three push buttons are used to control the ventilation, the lighting and to stop the alarm.

Pressing the ON/OFF ventilation button on the HMI controls a fan and/or a motorised damper via the two relays VENT 1 and VENT 2.

It allows to regulate the ventilation according to 2 operating points determined by the position of the sash.

- In the low position, the controller sends a first fixed voltage.
- In high position, the controller sends a second fixed voltage.

The switch allows to alternate from one speed to another. The controller ensures both the safety of the operator and an important energy saving.

The green LED is lit when the face velocity is sufficient.

The red LED flashes when the face velocity is insufficient.

The orange «sash overrun» LED lights up if the sash is raised above the maximum safe working opening. This fault is triggered by a position switch.

If a failure remains within a period of time of 15-30s, the audible alarm will activate. Having identified the problem, the laboratory personnel can stop the alarm by pushing the stop buzzer button.

Pressing the light ON/OFF button controls the lighting via a 250V 16A relay.

The controller is supplied with a 230V/12V power adaptor.

The controller is factory preset to 0.5m/s and can be reset on site using an anemometer.

# CONTROL SEAT

REF 819730

## The CONTROL SEAT is a safety device for controlling the ventilation of a fume hood.

It adjusts the ventilation to maintain the set speed regardless of the sash height. It informs the user with visual and audible alarms if a malfunction occurs. The remote HMI enables adjustments on site and controls the fume hood ventilation.

It has many operating modes and can be combined with a linear position sensor (see page 31).



## ADVANTAGES

- Digital display of speed and/or flow rate
- Remote HMI with small dimensions to control the fume hood ventilation and to make adjustments on site
- Energy savings: reduction of exhaust air by regulation
- Flexibility: the fan can be set to any speed
- User comfort: low air velocities ensure low noise levels
- Easy to use, install and maintain
- Visual and audible alarms
- Pre-calibrated to 0.5m/s
- EN 14175 compliant



✓ This controller is EN 14175 and RoHS compliant

HMI Dimensions  
115x65x18

CPU Dimensions  
241x182x65

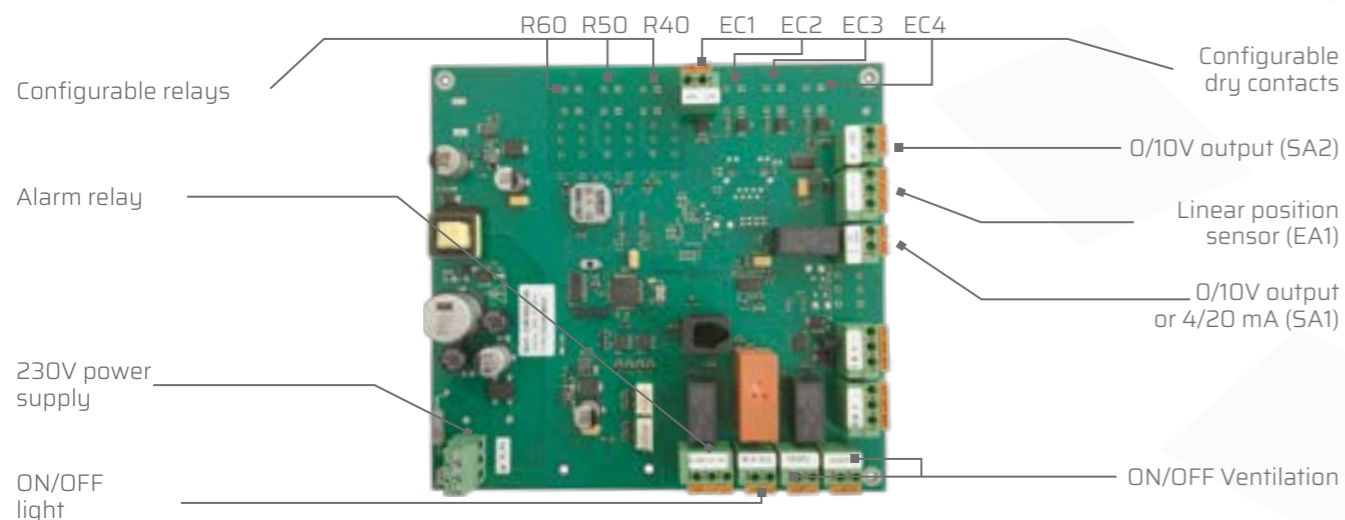

## DIAGRAM

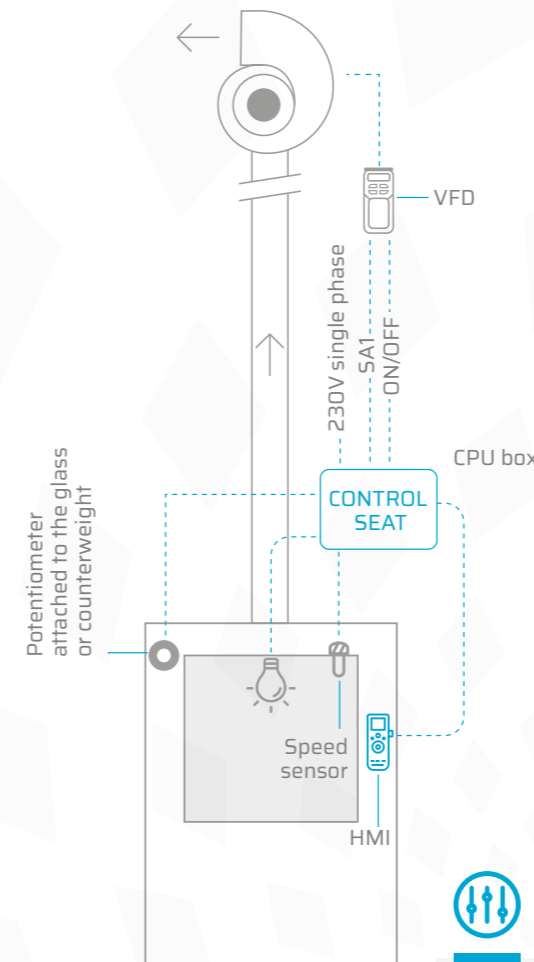

## OPTIONS

- Temperature sensor
- Night setback
- Linear position sensor (p.31)
- Speed sensor with 5 metres wire

### • Additional configurable dry contacts option

By default the controller is equipped with an EC1 all or nothing input, but it is possible to have up to 4 inputs as an option to perform various actions. These inputs can be used, for example, to add remote controls such as emergency stop, priority speed, reduced flow, night setback or second speed. Various sensors can also be connected to these additional inputs. These can control ventilation, light, alarm or configurable outputs.

### • Additional configurable relays option

Up to 3 additional outputs are available as options. These are relay outputs (NO 250V 0.3A) that can be used to control all kinds of electrical equipment such as solenoid valves, inverters and motors requiring dry contact control. These outputs can be controlled by the HMI push buttons, configurable inputs or window heights.

## OPERATING PRINCIPLE

The CONTROL SEAT is used to control the airflow of a fume hood.

Six push buttons are used to control the ventilation, the lighting, priority speed, navigate menus and to stop the alarm.

Pressing the ON/OFF button on the HMI controls a VFD and/or a motorised damper via the two relays VENT 1 and VENT 2.

A linear position sensor (optional) allows to measure the height of the window and thus to regulate the airflow (linear or multi-speed).

This flow rate variation is achieved by sending a 0/10V signal to the VFD or the motorised damper.

The control can also be performed with the sensor only (PID controller) or with a position switch (2-speed).

The sensor measures the face velocity, which informs the user in case of a fault.

The green LED is lit when the face velocity is sufficient.

The red LED flashes when the face velocity is insufficient.

The orange «sash overrun» LED lights up if the maximum window height is exceeded. This fault is activated by the linear position sensor or by a position switch.

The orange LED «auxiliary faults» lights up if the auxiliary input is activated.

The audible alarm is activated after an adjustable delay when a fault is still present. After identifying the cause, the user can turn off this alarm by pressing the stop buzzer button.

Pressing the light ON/OFF button controls the lighting via a 250V 16A relay.

The controller is powered by 230V single phase. The controller is factory preset to 0.5m/s and can be adjusted on site using an anemometer.

- 6 configurable push buttons for navigating the setting menus.
- Contact for air compensation.
- Emergency extraction / Speed priority.
- 2 x 0/10V outputs, one of which can be configured as 4-20mA.
- Alarm relay and battery backup.

# MODULAR CONTROLLER CONTROL E-SEAT

REF 819732

## The CONTROL E-SEAT is a communicating safety device for controlling the ventilation of a fume hood.

It adjusts the ventilation to maintain the selected speed set point regardless of the sash height. It informs the user with visual and audible alarms if a malfunction occurs. The remote HMI enables adjustments on site and controls the fume hood ventilation. It has many operating modes and can be associated with a linear position sensor (see page 31).

**A MODBUS connection is provided to link all CONTROL E-SEAT boards and interface them with a CAPTUR E-SEAT board and/or a CTM.**



## ADVANTAGES

- Communicating controller: MODBUS link
- Digital display of speed and/or flow rate
- Remote HMI with small dimensions to control the fume hood ventilation and to make adjustments on site
- Energy savings: reduction of exhaust air by regulation
- Flexibility: the fan can be set to any speed
- Comfortable to use: low air speeds ensure low noise levels
- Easy to use, install and maintain
- Visual and audible alarm
- Pre-calibrated to 0.5m/s
- EN 14175 compliant

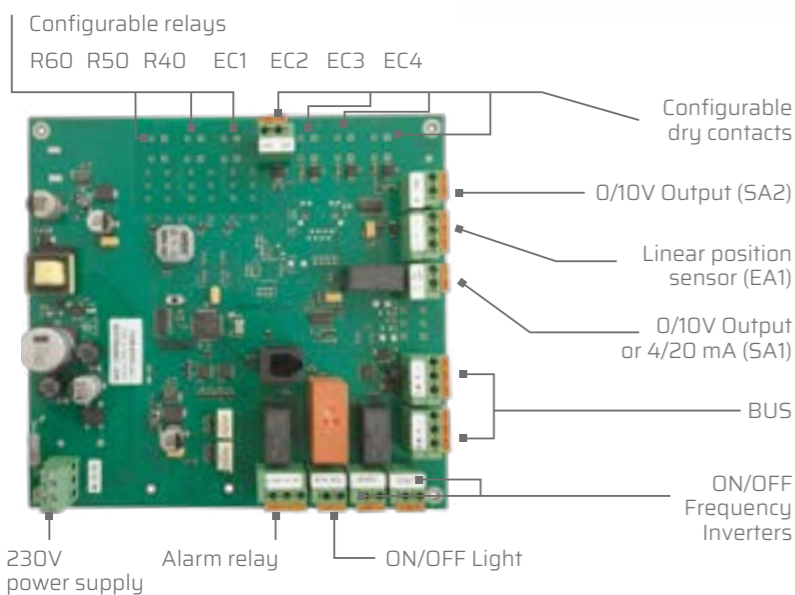

✓ This controller is EN 14175 and RoHS compliant

**HMI Dimensions**  
115x65x18

**CPU Dimensions**  
241x182x65

## DIAGRAM

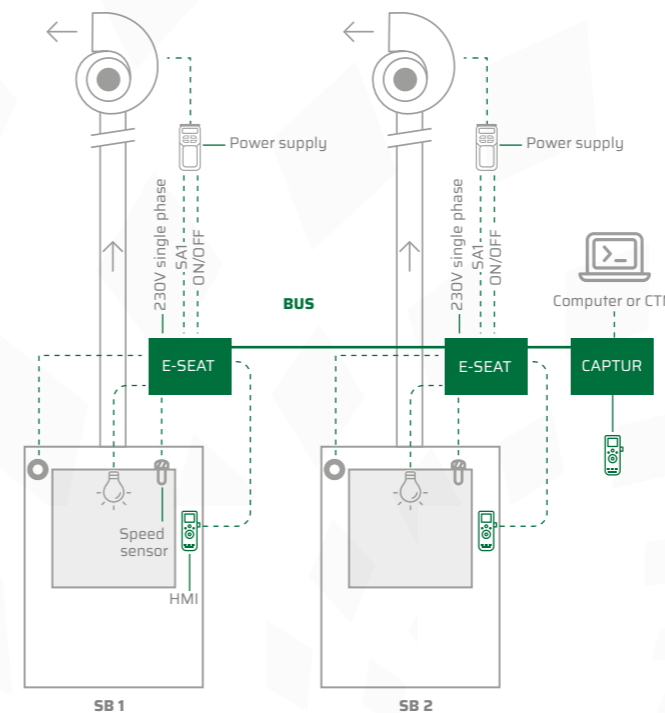

## OPTIONS

- Linear position sensor (p.31)
- Temperature sensor
- Night setback
- Speed sensor with 5 metres wire

### • Additional configurable inputs option

By default the controller is equipped with an EC1 input, but up to 4 inputs are available as options to perform various functions. These inputs can be used, for example, to add remote controls such as emergency stop, priority speed, reduced flow, night setback or second speed. Various sensors can also be connected to these additional inputs. These can control ventilation, light, alarm or configurable outputs.

### • Additional configurable outputs option

Up to 3 additional outputs are available as options. These are relay outputs (NO 250V 0.3A) that can be used to control all kinds of electrical equipment such as solenoid valves, drives and motors that require dry contact control. These outputs can be controlled by the interface buttons, by the configurable inputs or by window heights.

## OPERATING PRINCIPLE

**The Control E-SEAT is used to control the airflow of the fume hood.**

Six push buttons are used to control the ventilation, the lighting, priority speed, navigate menus and to stop the alarm.

Pressing the ON/OFF button on the HMI controls a VFD and/or a motorised damper via the two relays VENT 1 and VENT 2.

The control can also be performed with the sensor only (PID controller) or with a position switch (2-speed).

The sensor measures the face velocity, which informs the user in case of a fault.

The green LED is lit when the face velocity is sufficient. The red LED flashes when the face velocity is insufficient.

The orange «sash overrun» LED lights up if the maximum window height is exceeded. This fault is activated by the linear position sensor or by a position switch.

The orange LED «auxiliary faults» lights up if the auxiliary input is activated.

The audible alarm is activated after an adjustable delay when a fault is still present. After identifying the cause, the user can turn off this alarm by pressing the stop buzzer button.

Pressing the light ON/OFF button controls the lighting via a 250V 16A relay.

The controller is powered by 230V single phase. The controller is factory preset to 0.5m/s and can be adjusted on site using an anemometer.

- 6 configurable push buttons for navigating the setting menus.
- Contact for air compensation.
- Emergency extraction / Speed priority.
- 2 x 0/10V outputs, one of which can be configured as 4-20mA.
- Alarm relay and battery backup.

# MODULAR CONTROLLER

## L.COM E-SEAT

REF 819733

**The L.COM E-SEAT board allows to control the airflow of exhaust arms, fume hoods and other ventilated stations with fixed airflow in a laboratory.**

Up to 3 extraction stations can be connected to the same controller with a programmable flow rate per station (P1, P2, P3).

The remote HMI enables adjustments on site and controls the fume hood ventilation.

**A MODBUS connection is provided to link all the L.COM E-SEAT boards with the CONTROL E-SEAT and interface them with a CAPTUR E-SEAT board and/or a BMS.**



### ADVANTAGES

- Communicating controller: MODBUS link
- Control of 1 to 3 stations with a specific flow rate for each station
- Control of a station with 3 different flow rates



✓ This controller is EN 14175 and RoHS compliant

HMI Dimensions  
115x65x18

CPU Dimensions  
241x182x65

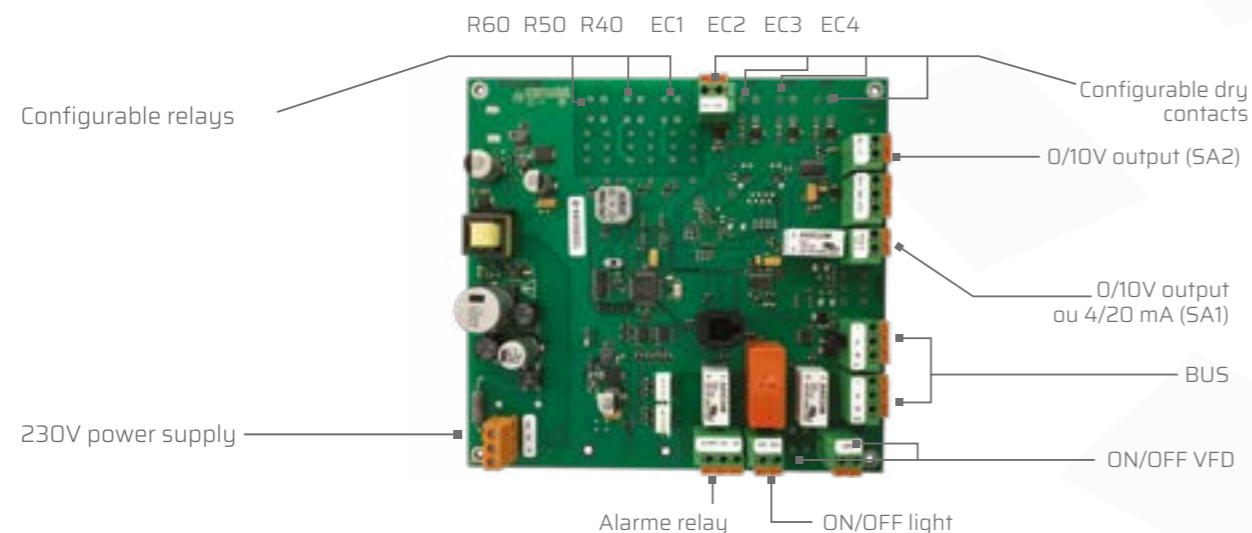

### DIAGRAM

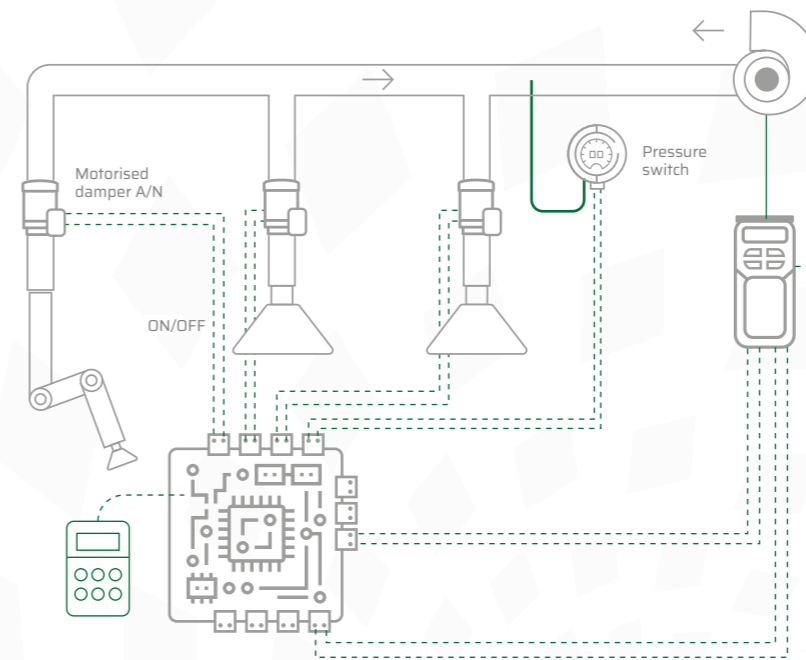

### OPTIONS

- Alarm relay
- Night setback
- Pressure switch (REF 819711)
- Optional alarm relay and battery backup
- Configurable inputs
- Additional configurable outputs

#### • Additional configurable inputs option

By default the controller is equipped with an EC1 input, but up to 4 inputs are available as options to perform various functions. These inputs can be used, for example, to add remote controls such as emergency stop, priority speed, reduced flow, night setback or second speed. Various sensors can also be connected to these additional inputs. These can control ventilation, light, alarm or configurable outputs.

#### • Additional configurable outputs option

Up to 3 additional outputs are available as options. These are relay outputs (NO 250V 0.3A) that can be used to control all kinds of electrical equipment such as solenoid valves, drives and motors that require dry contact control. These outputs can be controlled by the interface buttons, by the configurable inputs or by window heights.

### OPERATING PRINCIPLE

**The L.com E-SEAT is used to control the airflow of exhaust arms and fume hoods.**

Six push buttons are used to control the ventilation, the lighting, priority speed, navigate menus and to stop the alarm.

#### Configuration 1 :

Up to 3 ventilation stations can be connected to the same controller with a programmable flow rate per station. The push buttons 3, 4 and 6 then control the ventilation of stations 1, 2 and 3 respectively.

#### Configuration 2 :

Several extraction flows can be configured on a single exhaust station. Each button (3,4,6) is associated with a configurable flow rate.

Pressing one or more of these buttons activates the VFD and/or a motorised damper via the two relays VENT 1 and VENT 2.

An optional pressure switch can be connected to inform the user in case of ventilation failure.

The green LED lights up when the pressure is sufficient.

The red LED flashes when the pressure is insufficient.

The orange LED «auxiliary faults» lights up if the auxiliary input is activated.

The audible alarm is activated after an adjustable delay when a fault is still present. After identifying the cause, the user can turn off this alarm by pressing the stop buzzer button.

Pressing the ON/OFF light button controls the lighting via a 250V 16A relay.

The controller is powered in 230V single phase.

- 6 configurable push buttons for navigating the setting menus.
- Contact for air compensation.
- Emergency extraction / Speed priority.
- 2 x 0/10V outputs, one of which can be configured as 4-20mA.
- **Up to 31 boards can be connected in series**
- Alarm relay and battery backup.

# MODULAR CONTROLLER CAPTUR E-SEAT

REF 819736

The CAPTUR E-SEAT board ensures a global management of the laboratory by controlling both the extraction and air supply.

It centralises the information from the CONTROL E-SEAT and/or L.COM E-SEAT boards via a MODBUS interface and sends them to an AHU and/or a BMS. It can also dialogue with a PC via an Ethernet TCP/IP connection.. The CAPTUR E-SEAT board allows to control of **up to 31 fume hoods** or other exhaust stations directly from the HMI or from a monitoring software on PC. It recovers information on flow rates, defaults, and emits visual and audible alarms in case of malfunctions.



## ADVANTAGES

- Two MODBUS link
- Two configurable 0/10V outputs
- TCP/IP ethernet links
- Overall control of a laboratory
- Control of several laboratories
- Connection to Supervision software



✓ This controller is EN 14175 and RoHS compliant

HMI Dimensions  
115x65x18

CPU Dimensions  
241x182x65

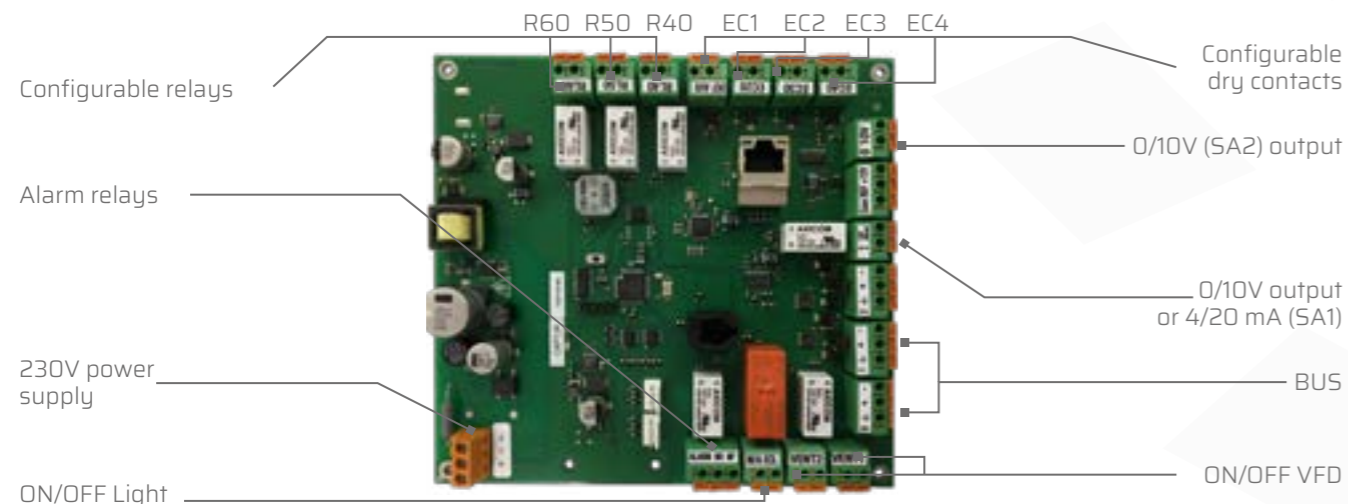

## DIAGRAM

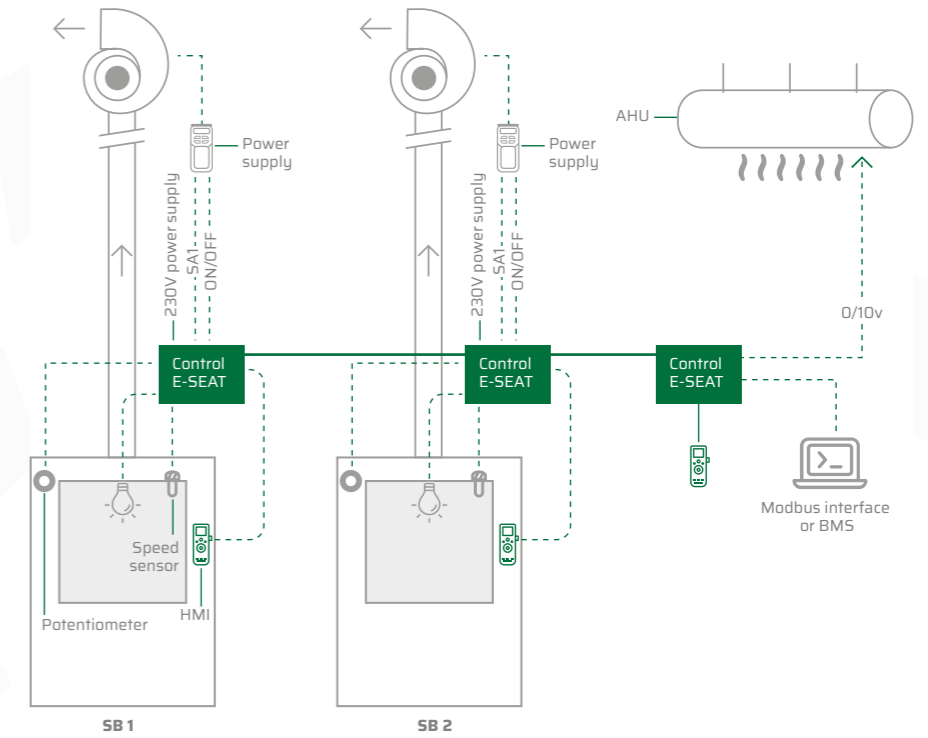

## OPERATING PRINCIPLE

The CAPTUR E-SEAT board is a remote control flow summing device. It enables the user to control the Control E-SEAT and L.COM E-SEAT boards installed on fume hoods, exhaust arms and exhaust hoods. It recovers the flow rates of each CONTROL E-SEAT and L.COM and sends back a 0/10V signal at the room air supply, signal which is proportional to the extraction. The 0/10V outputs can be adjusted with a coefficient in order to have a more accurate setting. It has a second MODBUS link to communicate with a BMS, and also an Ethernet TCP/IP link to communicate with a monitoring software. A remote HMI allows to control the functioning of all the connected boards

- ON/OFF Light
- ON/OFF ventilation
- Priority speed
- Stop alarm
- Configurable push buttons

The control of these functions can also be done through the Supervision software connected to the RJ 45 of the CAPTUR E-SEAT.

The controller is powered by single phase 230V. The CAPTUR E-SEAT board has 4 configurable inputs to perform various functions such as emergency stop, priority speed, reduced flow or night watch. Different sensors can also be connected to these additional inputs which can control ventilation, light, alarm or configurable outputs..

It has 3 output relays (NO 250V 0.3A) which allow to control all kinds of electrical equipment requiring a dry contact control such as solenoid valves, inverters, motors and dampers. These outputs can be controlled by the interface buttons or by the configurable inputs.

Do not hesitate to view examples of installations at the end of the catalog.



## OPTIONS

Two SUPERVISION software for Windows PC are available as options.

Enables you to centralise all the useful data for the management of laboratories and stations. It is possible to remotely control each station or an entire laboratory and is the ideal tool to maintain laboratories on a daily basis.



REMOTE HMI CONTROLLER  
FULLY INTEGRATED CONTROLLER  
MODULAR CONTROLLER  
SAFETY OR STORAGE CABINET CONTROLLER  
ECOGLOSS  
ACCESSORIES  
EXAMPLES OF INSTALLATIONS  
THE COMPANY

# SAFETY CABINET CONTROLLER

REF 819697

## The enclosed controller measures the working time of the extraction in the ventilated enclosure.

If the timespan is inferior to 5% of the initial setting time, 2 orange lights flash to notify the lab assistant (☒).

When the operating time has elapsed, the controller informs the users by displaying «FIL» (abbreviation of: filters to be changed), and triggers two alarms: an audible alarm and a visual alarm (the two orange LEDs remain lit).

In the event of an extraction failure (insufficient suction, open door, blocked filter, air flow failure...), The red LED flashes and the sound alarm is activated. If the flow is sufficient the green LED comes on.

Airflow, lighting, and the stop buzzer are controlled by 3 push switches.



### ADVANTAGES

- Simple interface for ventilation and light control
- Visual and audible alarm in case of ventilation failure
- Can be adjusted to suit any ventilation system
- Accurate probe measurements



### OPTIONS

- Alarm relay
- Temperature sensor
- Remote speed probe (3.5m or 5m)

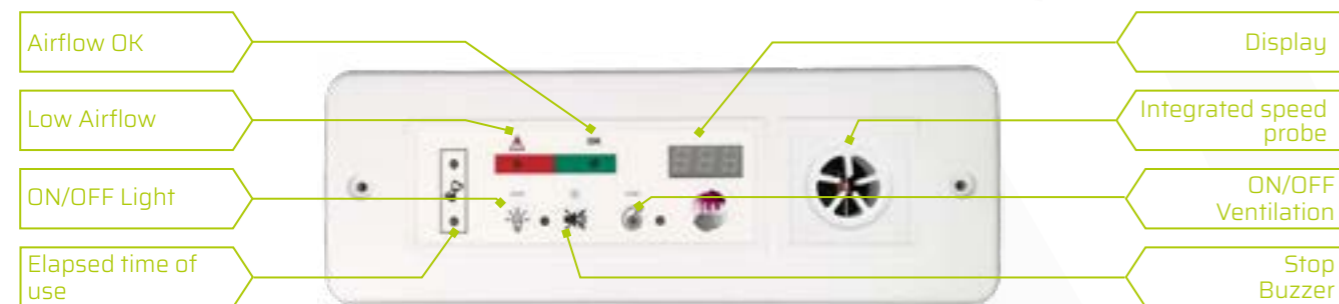

✓ This controller complies with EN 14175 and the work regulation R4222-13

HMI Dimensions  
210x75x34

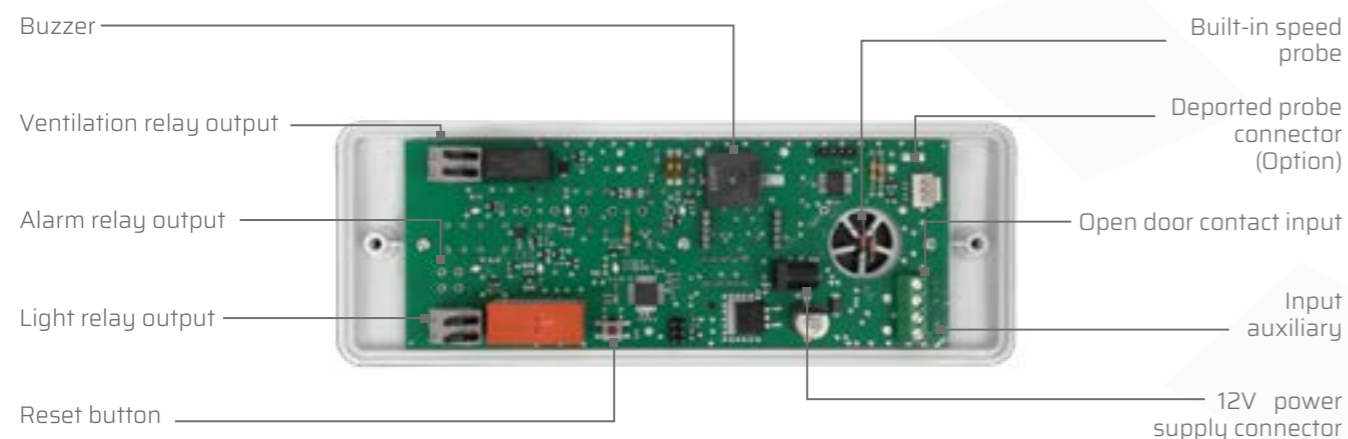

# STORAGE CABINET CONTROLLER

REF 819696



### ADVANTAGES

- Simple interface for ventilation and light control
- Visual and audible alarms in case of ventilation failure
- Can be adjusted to suit any ventilation system
- Accuracy of probe measurement



### OPTIONS

- Alarm relay
- Temperature sensor
- Remote speed probe (3.5m or 5m)

## This controller is used to check the correct operation of the extraction of a chemical storage cabinet.

In case of an extraction fault (insufficient suction, open door, clogged filter, fan failure,...), the red LED flashes and the acoustic alarm is activated. If the flow rate is sufficient, the green LED is lit.

The installation of this product requires the drilling of a panel or door in the cabinet.

# AUTOMATIC INACTIVITY CONTROLLER

## ECOGLASS

REF 819740

**ECOGLASS is an efficiency optimised system designed to reduce fume hood energy consumption by automatically closing a moveable sash after detecting inactivity.**

A motion sensor detects the activity of laboratory personnel and the presence of objects in the path of the sash. The ECOGLASS controller recognises and acts upon a period of pre-programmed inactivity and automatically triggers the lowering command to close the sash to its lowest point. A magnetic compensator releases the sash and controls its descent to the end of its path. A safety device then interrupts the descent in case of activity or objects in the sashes path while a control switch allows laboratory operatives to disengage the magnetic compensator, allowing them to operate the sash.

### OPERATING PRINCIPLE

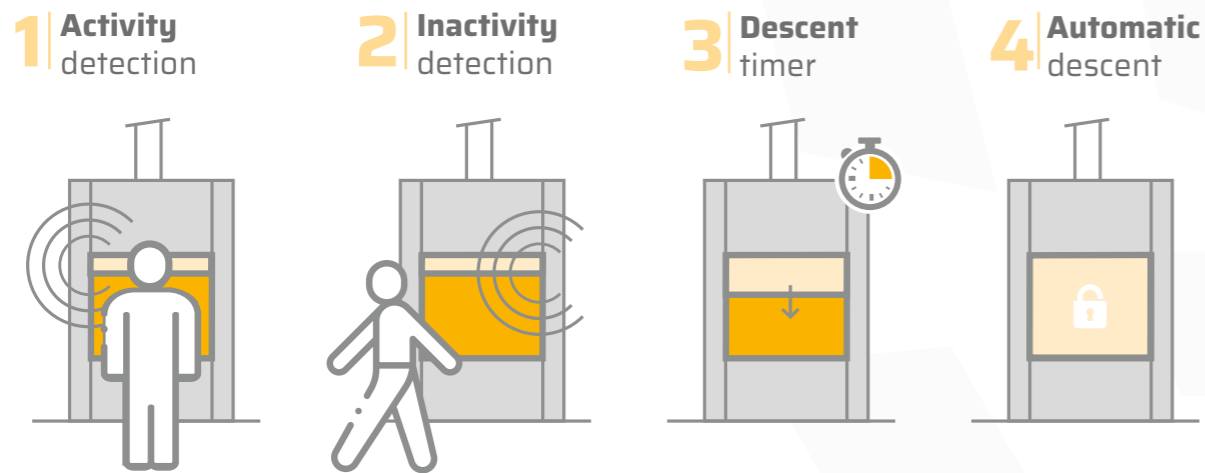

✓ This controller complies with EN 14175 and the work regulation R4222-13

🔄 **Detection zone dimensions**  
H = 0,40m, Up to 2.5 metres in width



### DIAGRAM

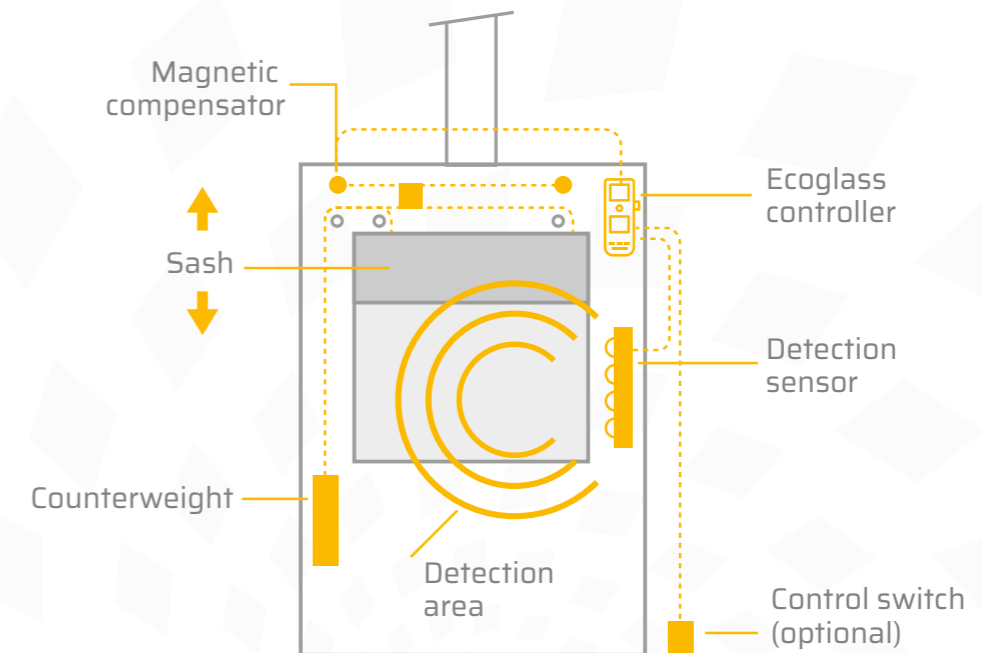

### FEATURES

**Automatic closing**  
After a configurable period of inactivity, whatever the initial position of the window, it is closed to its lowest point. The detection sensor can be installed on the front of the sash or flush-mounted.

**Inactivity sensor**  
Movement generated by a weight imbalance between the sash and its counterweight.

**No motorization**  
Ecoglass allows the handling of the fume hood with or without power and ensures that the glass remains in position.

**Installation**  
Different configurations are possible depending on the position of the counterweight and the type of mechanisms (compatible with cable or belt transmission).



### ADVANTAGES

- Automatic descent without motorization
- Adapts to all movable sash mechanisms.
- Quick installation without modification of the fume hood

REMOTE HMI CONTROLLER  
FULLY INTEGRATED CONTROLLER  
MODULAR CONTROLLER  
SAFETY OR STORAGE CABINET CONTROLLER  
ECOGLASS  
ACCESSORIES  
EXAMPLES OF INSTALLATIONS  
THE COMPANY

# ACCESSORIES INVERTERS

## OPERATING PRINCIPLE

VARIABLESEAT VFDs are specifically configured for each SEAT fan. Providing motor protection in all applications, allowing the fan speed to be varied to achieve significant energy savings, and adaptable to all electrical installation requirements :

- Single-phase 230V input / Three-phase 230V output
- Three-phase 400V input / Three-phase 400V output
- Output frequency range: 15Hz to 60Hz



## RANGE

References	Power (kW)	Pole number	Motor speed	230V 1ph	400V 3ph	SEAT Series	JET Series	STORM Series
<b>VARIABLESEAT400</b>	0,37	6	1000	Yes	Yes	SEAT 15,20,25	JET 20, 25	
		4	1500	Yes	Yes	SEAT 15, 20, 25	JET 20, 25	STORM 10, 12
		2	3000	Yes	Yes	SEAT 15		STORM 10, 12
<b>VARIABLESEAT750</b>	0,75	6	1000	Yes	Yes	SEAT 30	JET 30	
		4	1500	Yes	Yes	SEAT 25	JET 25	
		2	3000	Yes	Yes	SEAT 20	JET 20	
<b>VARIABLESEAT1100</b>	1,1	4	1500	Yes	Yes	SEAT 30	JET 30	
		2	3000	Yes	Yes	SEAT 20	JET 20	STORM 14
<b>VARIABLESEAT1500</b>	1,5	8	750	Yes	Yes	SEAT 35		
		2	3000	Yes	Yes	SEAT 25	JET 25	
<b>VARIABLESEAT2200</b>	2,2	6	1000	Yes	Yes	SEAT 35		
		2	3000	Yes	Yes	SEAT 25	JET 25	STORM 16
<b>VARIABLESEAT4000</b>	4	4	1200	No	Yes	SEAT 50		
		4		No	Yes	SEAT 35		
		2		No	Yes	SEAT 25	JET 25	
<b>VARIABLESEAT5500</b>	5,5	4	1500	No	Yes	SEAT 35, 50		



## ADVANTAGES

- Improves motor performances
- Energy savings
- Motor protection, reduction of starting current, extension of service life
- Special settings for fan applications
- Specific settings for each of our fans
- Settings for ATEX motors
- Numerous wiring configurations
- Available in IP66 version
- Available for EC motors

## Features

- Connection to SEAT controllers: C, C2Speed, CONTROL SEAT, CONTROL E-SEAT, L.COM E-SEAT, CAPTUR E-SEAT
- 0-10V or 4-20mA control
- Preset/priority speeds
- Management of potentiometers
- PTC sensor connection
- 0-10V output to other equipment (motorised dampers, etc.)

## ACCESSORIES TRIP SWITCH REF 819716



## OPERATING PRINCIPLE

The trip switch provides a dry contact connection when the laboratory fume hood sash is raised above the trip switch installed location. The trip switch can be applied with SEAT controllers to detect sash overrun and/or to perform the second speed for the Type-C two-speed controller.



**Dimensions**  
39 x 32 x 15mm (WxHxL)

## ACCESSORIES MOTORISED DAMPER

## OPERATING PRINCIPLE

Motorised dampers provide ON/OFF or proportional flow control.



## ADVANTAGES

- Connection to SEAT controllers: Type A, Type C, Type C2V, CONTROL SEAT, CONTROL E-SEAT, L.COM E-SEAT, CAPTUR E-SEAT
- PVC made
- ON/OFF version in 230V controlled by contact
- Proportional version in 24V (AC or DC) controlled by 0-10V signal

## ACCESSORIES POTENTIOMETER REF 819609

## OPERATING PRINCIPLE

For manual flow control.  
Compatible with 0-10V VFDs



**Dimensions**  
51 x 70 x 100 (WxHxL)

## ACCESSORIES LINEAR POSITION SENSOR REF 819608



## OPERATING PRINCIPLE

Usually associated with the CONTROL SEAT or CONTROL E-SEAT, the linear sensor makes it possible to determine the position of the fume hood sash in order to provide a precise and proportional regulation of the ventilation with a wire fixed on a mobile part of the fume hood. (Maximum length: 1.20 m.)



**Dimensions**  
103 x 95 x 57mm (WxHxL)

## Motorised damper range :

	Diameter	Length	Reference
<b>Damper 125mm</b>	Ø125	140	<b>817125</b>
<b>Damper 160mm</b>	Ø160	180	<b>817160</b>
<b>Damper 200mm</b>	Ø200	225	<b>817200</b>
<b>Damper 250mm</b>	Ø250	265	<b>817250</b>
<b>Damper 315mm</b>	Ø315	305	<b>817315</b>

## ON/OFF Motorisation

Réf : 817100

Controlled by dry contact  
Open/Close delay: 35s or other on request  
Power supply: 230 VAC

## Proportional Motorisation

Réf : 817102

Controlled by 0-10V signal  
Open/Close delay: 10s or other on request  
Power supply : 24V (AC or DC)  
230V/24V transformer option for 1 shutter (REF 040019)  
230V/24V transformer option up to 6 shutters (REF 040020)



# EXAMPLES OF INSTALLATIONS INDIVIDUAL EXTRACTION N°1

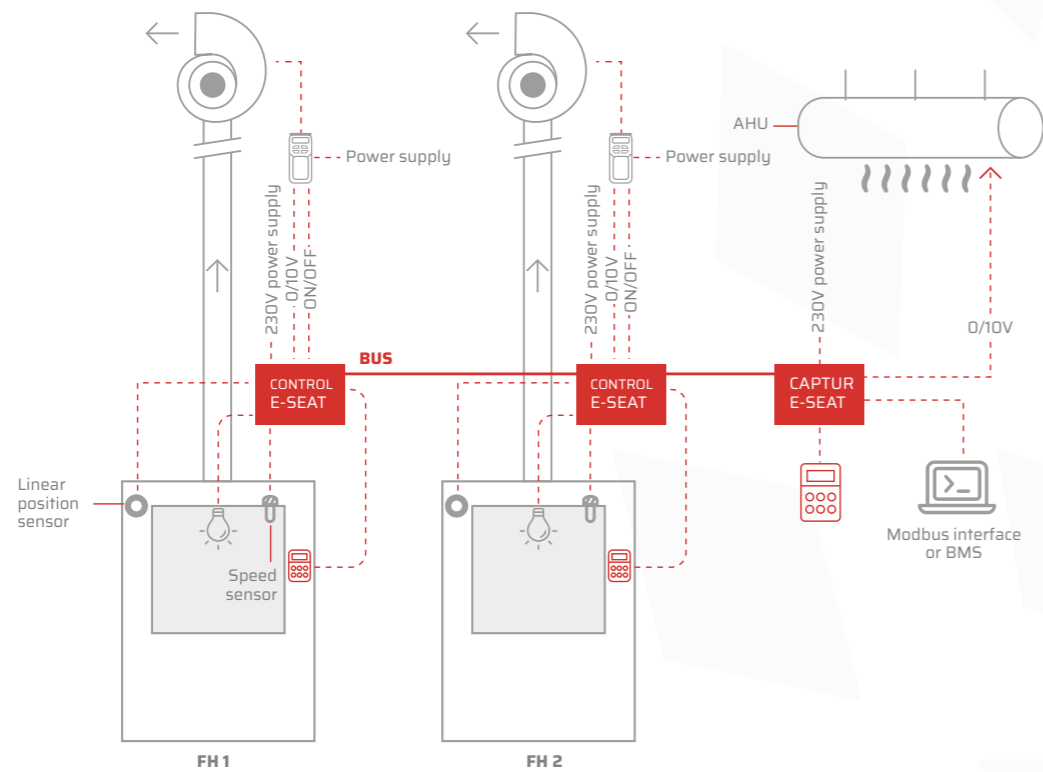

## OPERATING PRINCIPLE AND FEATURES :

In this configuration, the regulation E-SEAT controls the fume hoods independently.

When the operator switches on the CONTROL E-SEAT installed on the fume hood, a signal is sent to the VFD which starts the fan. The regulation of the exhaust air flow is managed by the linear position sensor which measures the height of the sash at all times. Thus, when the operator manipulates the sash, the exhaust airflow rate varies instantaneously. A speed sensor installed on the fume hood allows to check if the face velocity is 0.4 m/s as recommended by the INRS and the EN 14175 standard. If the 0.4 m/s set point is not achieved, the CONTROL E-SEAT will activate visual and audible alarms to warn the operator of a fault.

The two CONTROL E-SEAT boards are interconnected via a MODBUS serial link and send their information to the CAPTUR E-SEAT, which acts as a flow summing device and as a central control board for the laboratory. The CAPTUR E-SEAT can then communicate with a BMS and/or with an AHU via a 0/10V signal.



### THIS SYSTEM

#### INCLUDES :

- 2 CONTROL E-SEAT on fume hoods
- 1 CAPTUR E-SEAT
- 2 VFDs
- 2 Linear position sensors
- 2 fans

# EXAMPLES OF INSTALLATIONS INDIVIDUAL EXTRACTION N°2

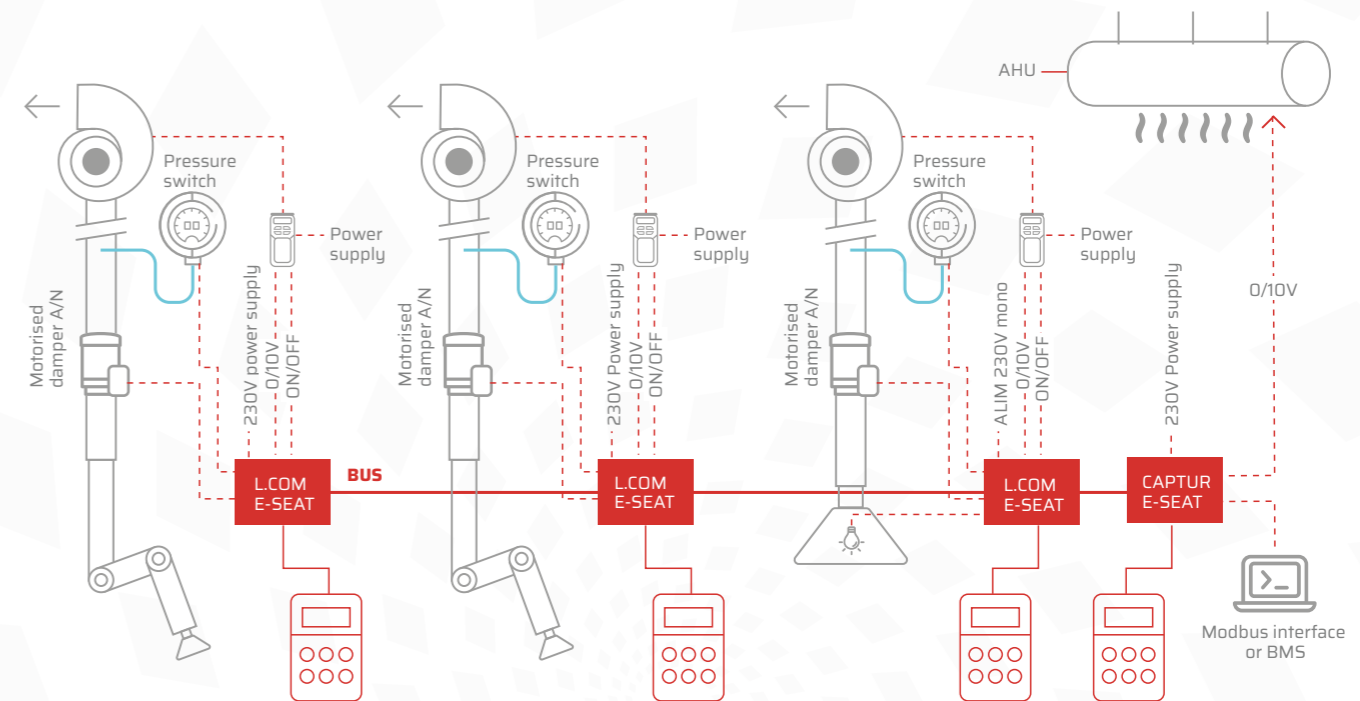

## OPERATING PRINCIPLE AND FEATURES :

In this configuration, the snorkel hoods are independently controlled by the L.COM E-SEAT.

When the operator switches on the L.COM E-SEAT installed near the snorkel hood, a signal is sent to the VFD which starts the fan. It is possible to set up to 3 different flow rates per arm which can be activated at any time by the user on the HMI. A pressure switch is installed on each snorkel hood to check if the extracted flow is sufficient. On each snorkel hood, a motorised damper is also installed, controlled by dry contact or 0/10V signal.

The three L.COM E-SEAT boards are interconnected via a MODBUS serial link and send their information to the CAPTUR E-SEAT, which acts as a flow summing device and as a central control board for the laboratory. The CAPTUR E-SEAT can then communicate with a BMS and/or with an AHU via a 0/10V signal.



### THIS SYSTEM

#### INCLUDES :

- 3 L.COM E-SEAT
- 3 pressure switches
- 1 CAPTUR E-SEAT
- 3 On/Off motorised dampers
- 3 VFDs
- 3 fans

## EXAMPLES OF INSTALLATIONS INDIVIDUAL EXTRACTION N°3

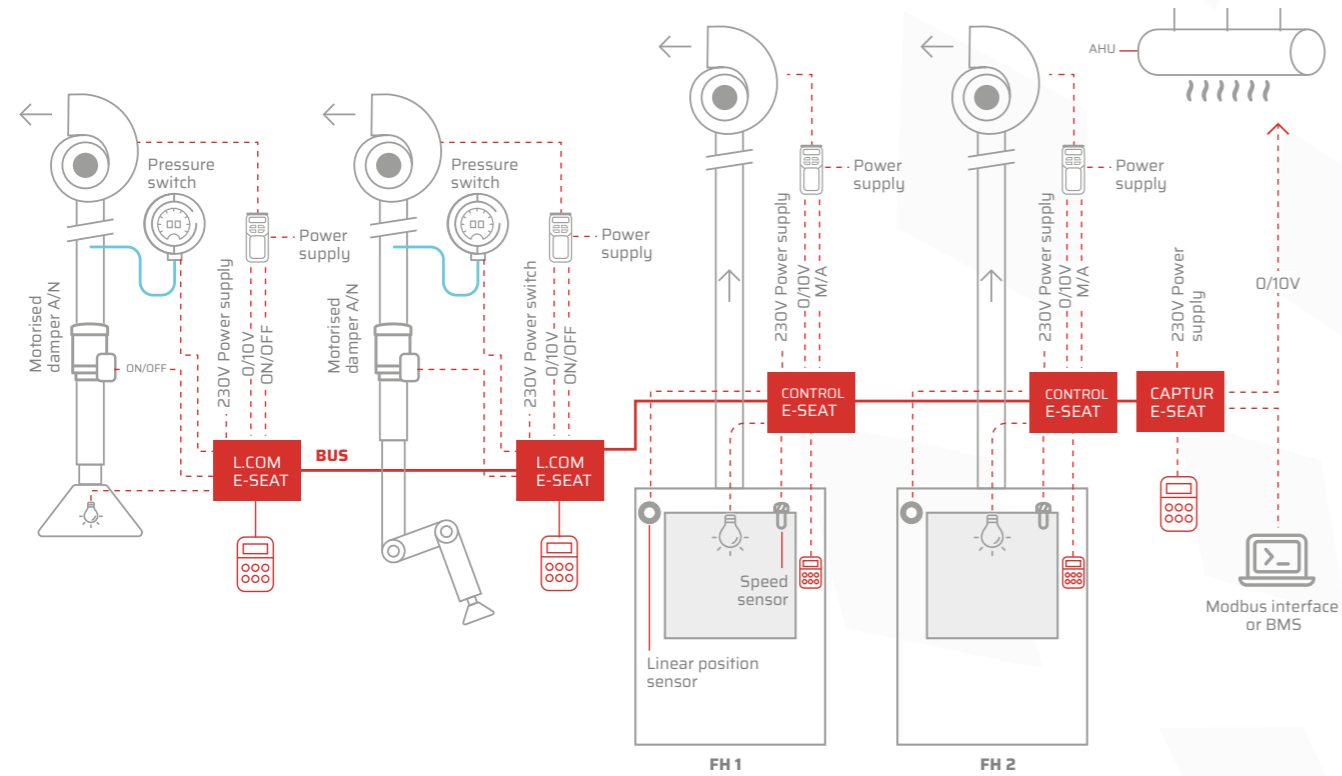

### OPERATING PRINCIPLE AND FEATURES :

In this configuration, the regulation system independently controls the fume hoods, the arm and the hood.

When the operator switches on the L.COM E-SEAT installed near the snorkel hood, a signal is sent to the VFD which engages the fan. It is possible to set up to 3 different flow rates per snorkel hood which can be activated at any time by the user on the HMI. A pressure switch is installed on each snorkel hood to check if the extracted flow is sufficient. On each snorkel hood, a motorised damper is also installed, controlled by dry contact or 0/10V signal.

When the operator switches on the CONTROL E-SEAT installed on the fume hood, a signal is sent to the VFD which engages the fan. The regulation of the exhaust air flow is managed by the linear position sensor which measures the sash height at all times. Thus, when the operator manipulates the sash, the exhaust airflow rate varies instantaneously. The speed sensor installed on the fume hood allows to check if the face velocity is 0.4 m/s as recommended by the INRS and the EN 14175 standard. If the 0.4 m/s set point is not achieved, the CONTROL E-SEAT will activate visual and audible alarms to warn the operator of a fault.

The L.COM E-SEAT and CONTROL E-SEAT cards are interconnected via a MODBUS serial link and send their information to the CAPTUR E-SEAT, which acts as a flow summing device and as a central control board for the laboratory. The CAPTUR E-SEAT can then communicate with a BMS and/or with an AHU via a 0/10V signal.

## EXAMPLES OF INSTALLATIONS MANIFOLD EXTRACTION N°1

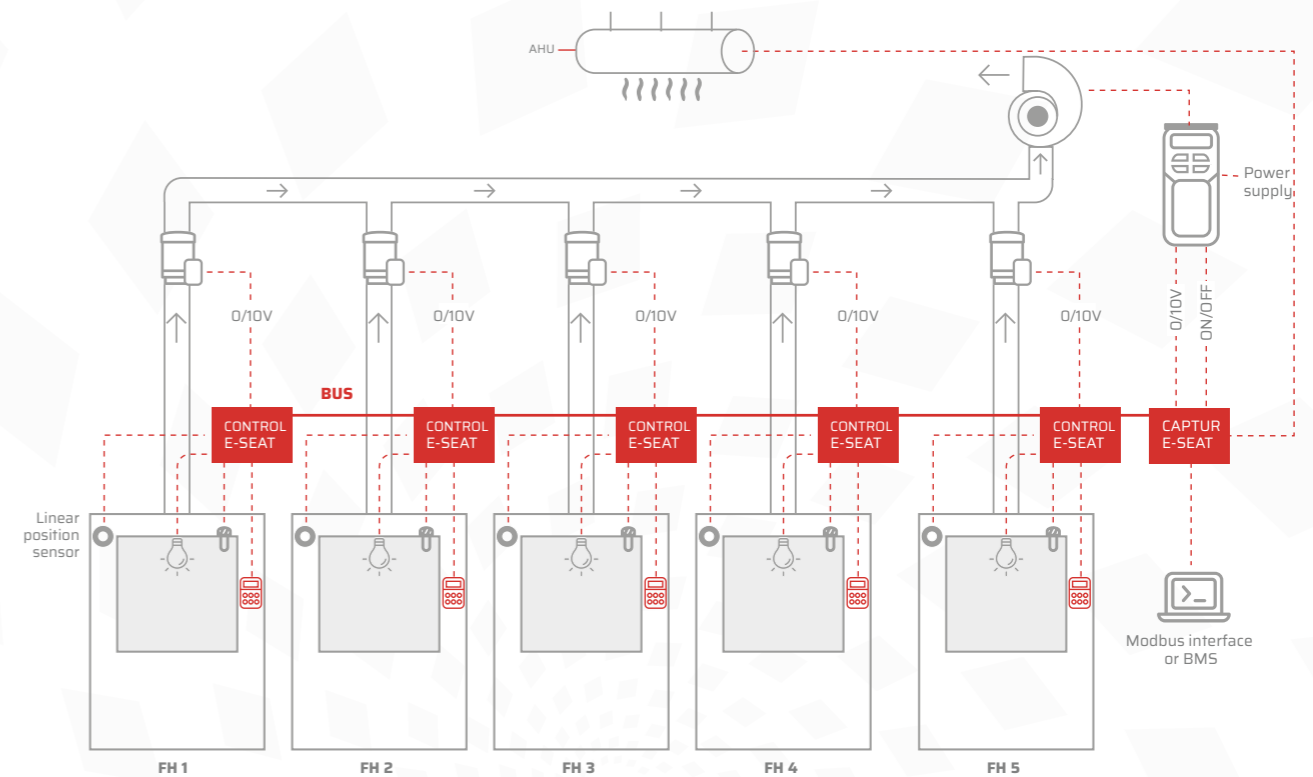

### OPERATING PRINCIPLE AND FEATURES :

In this configuration, each fume hood is equipped with a CONTROL E-SEAT. The extraction is performed by a single fan.

When one of the fume hoods is switched on, the fan is started via the VFD and the associated motorised damper is opened.

For each fume hood in operation, the exhaust airflow regulation is managed by the linear position sensor which measures the sash height at any time. Thus, when the operator manipulates the sash, the exhaust airflow varies instantaneously. A speed sensor installed on the fume hood checks whether the face velocity is 0.4 m/s as recommended by INRS and EN 14175. If the set point of 0.4 m/s is not achieved, the CONTROL E-SEAT will activate visual and audible alarms to warn the operator of a fault.

The five CONTROL E-SEAT boards are interconnected via a MODBUS serial link, and send their information to the CAPTUR E-SEAT, which acts as a flow summing device and as a central control board for the laboratory. The total flow rate to be extracted is then sent as a 0/10V signal to the VFD which controls the fan. The CAPTUR E-SEAT can then communicate with a BMS and/or an AHU via a second 0/10V signal.



### THIS SYSTEM INCLUDES :

- 5 CONTROL E-SEAT on fume hoods
- 1 CAPTUR E-SEAT
- 5 motorised 0/10V dampers
- 5 linear position sensor
- 1 VFDs
- 1 fan



### THIS SYSTEM INCLUDES :

- 2 L.COM E-SEAT
- 2 pressure switches
- 2 CONTROL E-SEAT on fume hoods
- 1 CAPTUR E-SEAT
- 2 On/Off motorised dampers
- 2 linear position sensors
- 4 VFDs
- 4 fans

## EXAMPLES OF INSTALLATIONS MANIFOLD EXTRACTION N°2

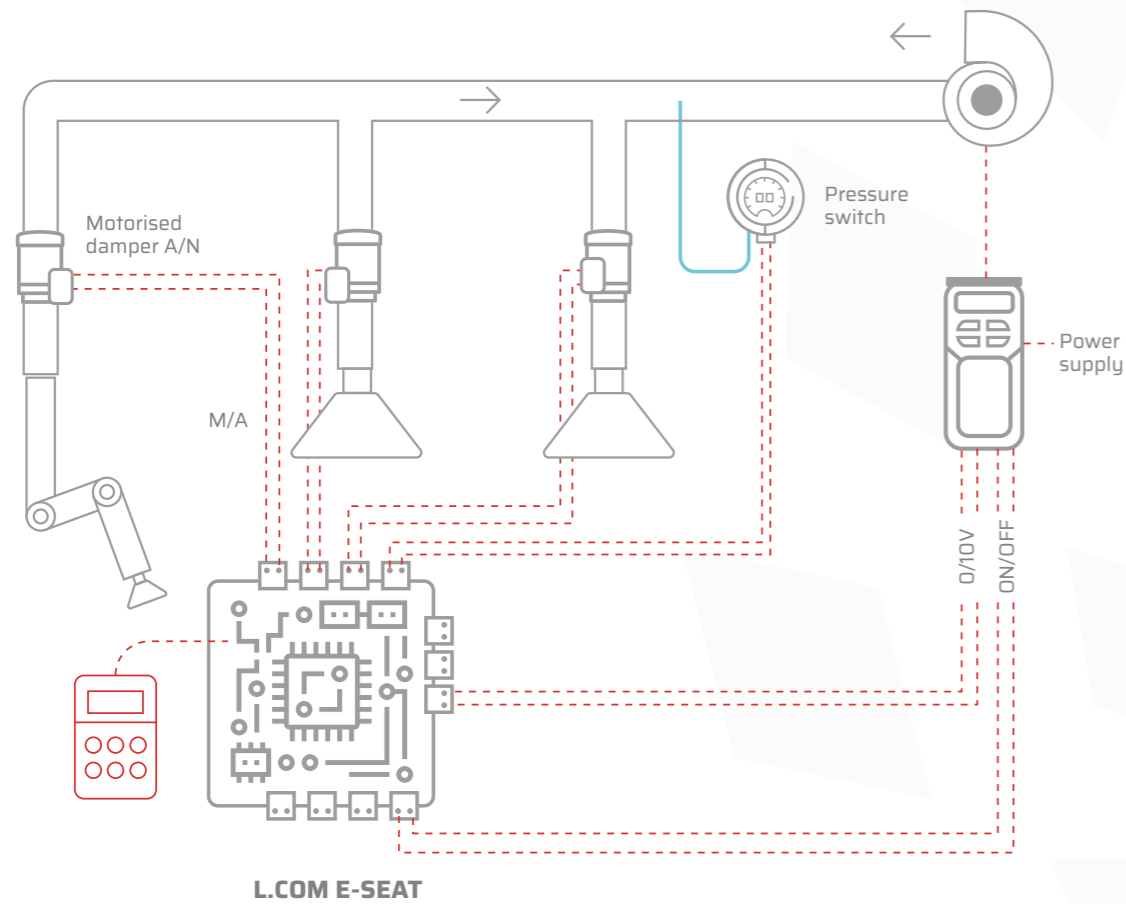

### THIS SYSTEM

#### INCLUDES :

- 1 L.COM E-SEAT
- 1 pressure switches
- 3 On/Off motorised dampers
- 1 VFD
- 1 fan

#### OPERATING PRINCIPLE AND FEATURES :

In this configuration, the L.COM E-SEAT controls both the snorkel hood and the two hoods. Extraction is performed by a single fan.

The L.COM E-SEAT has three push buttons (P1, P2, & P3), each assigned to a specific hood system. Each of these push buttons engage the blower and the dedicated motorised damper which is associated to the specific hood system. For each of the hood system, a flow rate has been set. The L.COM E-SEAT accumulates the flow rates of the operating units and sends the corresponding 0/10V signal to the VFD which controls the fan.

A pressure switch is installed upstream on the extraction network and allows to control if the flow rate is sufficient.

## EXAMPLES OF INSTALLATIONS MANIFOLD EXTRACTION N°3

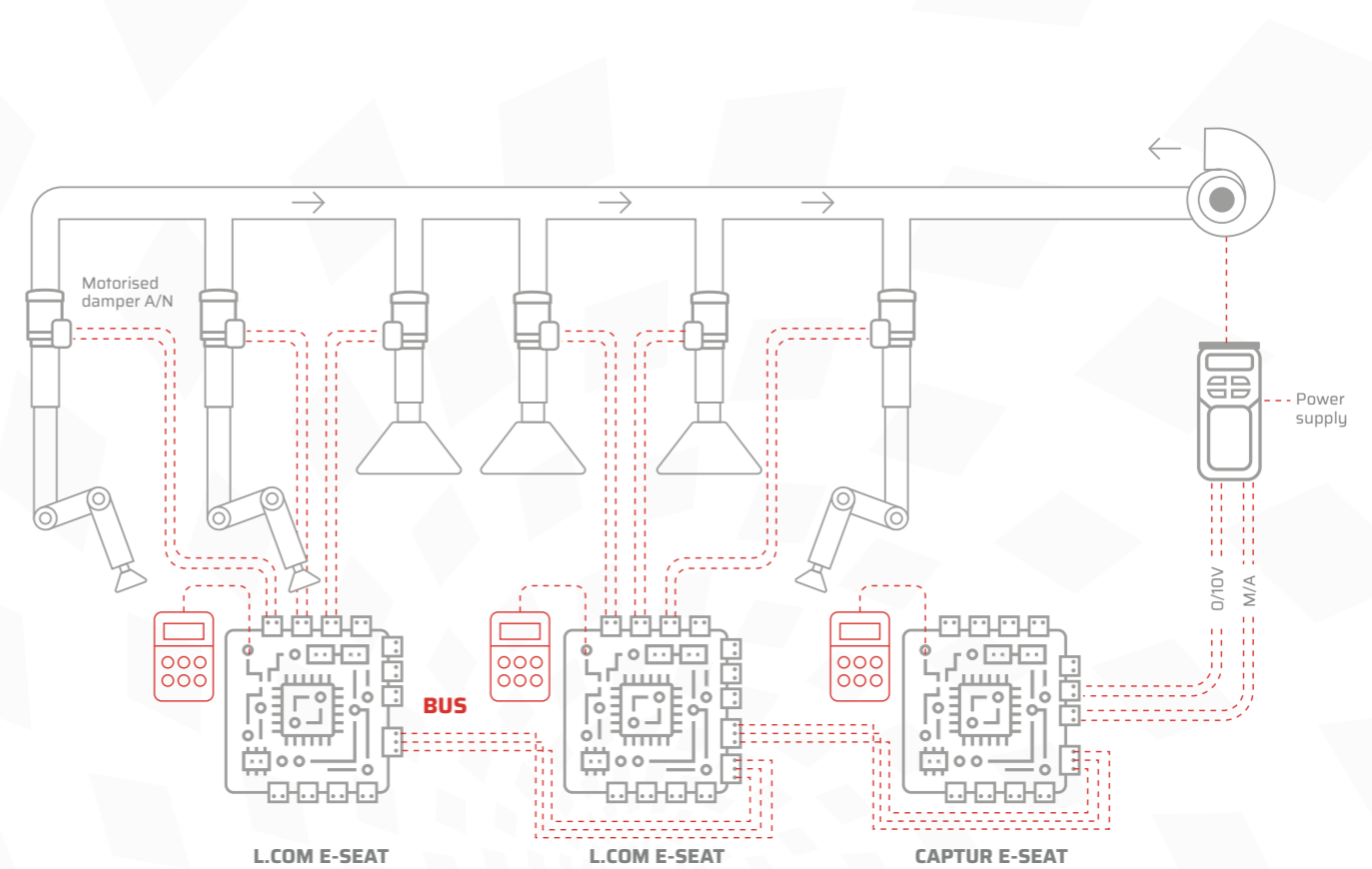

### THIS SYSTEM

#### INCLUDES :

- 2 L.COM E-SEAT on arms
- 1 CAPTUR E-SEAT
- 6 On/Off motorised dampers
- 1 VFD
- 1 fan

#### OPERATING PRINCIPLE AND FEATURES :

In this configuration, each L.COM E-SEAT controls three ventilation units. Exhaust is performed by a single fan.

The two L.COM E-SEAT have three push buttons (P1, P2, P3) each assigned to a ventilation unit. Each of these buttons switches on the general ventilation and opens the motorised damper associated with the extraction unit.

The L.COM E-SEAT boards are interconnected via a MODBUS serial link and send their information to the CAPTUR E-SEAT which acts as a flow rate summing device and general control board for the laboratory. The total flow rate to be extracted is then sent as a 0/10V signal to the VFD which controls the fan. The CAPTUR E-SEAT can then communicate with a BMS and/or an AHU via a second 0/10V signal.

# SEAT VENTILATION THE COMPANY



*"Our products are specially designed to be energy efficient, ensuring financial savings and a real impact on sustainable development."*

**Established in the Capital of France, Paris, SEAT Ventilation specialise in the extraction of corrosive and hazardous fumes with a distinctive range of ventilation components.**

Focusing on our laboratory clients and to complement the existing range of corrosion resistant fans, we have developed a range of airflow controllers that provide safety and security for systems and operatives working with fume extraction systems.

**The success of our company is determined by our actions and decisions centred around 4 fundamental values :**

**Technicality :** To remain attentive to our customers thanks to our team of engineers and specialised technicians.

**Reactivity :** To establish and maintain a close relationship with our customers, excel in the quality of service we offer and quickly respond to requests.

**Competitiveness :** Optimise and accelerate our processes by reducing costs, with French manufacturing, without ever losing sight of our customers' quality requirements.

**Innovation :** Constantly improve our products and develop new ones to better meet the needs and expectations of our customers.

Our mission is to be a key partner for our customers, developing safe, sustainable and user-friendly solutions.

# OUR TEST LABORATORY

**Our test laboratory is an integral part of our R&D and engineering.**

It allows us to develop and test our extraction and regulation products, using equipment certified to EN 14175 and INRS ED795 standards, in real operating situations.

**Come visit our LAB**



# WANT TO GO FURTHER ? OUR TRAINING COURSE



**We offer customised training programs on all our products specifically tailored to each individual customers needs. Whether for laboratory technicians, installing contractors, maintenance managers, etc. SEAT Ventilation provides training on :**

- Control and safety of laboratory ventilation
- Complete fan management system
- EN 14-175 standard
- Air conditioning / Air extractors / VFDs / Electric motors

**Our specialised electrical and HVAC engineers will introduce you to the work of L.SOLUTION extraction like no other.**

You can learn how to make the necessary adjustments during installation, as well as how to handle the equipment as required by the laboratory technicians, and to know the multiple options..

SEAT Ventilation is a member of the European Committee for Standardisation, CETIAT, Fabrilabo and AMCA International. You will also be able to follow specific training on French, European, ISO, AMCA and Fabrilabo standards.

**Interested in training at SEAT ? Get in touch with us !**

REMOTE  
HMI  
CONTROLLER

FULLY  
INTEGRATED  
CONTROLLER

MODULAR  
CONTROLLER

SAFETY OR  
STORAGE CABINET  
CONTROLLER

ECOGLOSS

ACCESSORIES

EXAMPLES OF  
INSTALLATIONS

THE COMPANY

# HIGH QUALITY PRODUCTS

Constructed with polypropylene, SEAT Ventilation fans are ideally suited for corrosive or toxic work environments.

Anti-UV & recyclable

High corrosion resistance

Highly resistant polypropylene

From 25 to 15 000 m<sup>3</sup>/h

T° Max 60°C

Single-phase or three-phase motors

Increased security

Wide range of products

Easy to install

## IDEAL FOR



Chemical industries and petrochemical plants



Pharmaceutical industries



Water treatment sites



Surface treatment and Agri-food industry



Swimming pools



Hospitals and Universities

Our fans are certified by AMCA



# A COMPLETE RANGE OF FANS

**SEAT Ventilation fans are the solution for exhaust air systems.** Made of polypropylene, a corrosion resistant material, they are ideal for corrosive and toxic gases and vapours. They are the safety solution in laboratories and for most highly exposed industrial applications.



## ADVANTAGES

The technical data of our fan range is already available for **BIM** software.

Used in laboratories and most industrial extractions. Simple to install, small in size and contain a good flow/pressure ratio.

## SEAT SERIES



**SEAT 15**  
Flow rate : 50-700 m<sup>3</sup>/h



**SEAT 20**  
Flow rate : 200-1600 m<sup>3</sup>/h



**SEAT 25**  
Flow rate : 500-3000 m<sup>3</sup>/h



**SEAT 30**  
Flow rate : 700-4500 m<sup>3</sup>/h



**SEAT 35**  
Flow rate : 1800-9000 m<sup>3</sup>/h



**SEAT 50**  
Flow rate : 5000-15000 m<sup>3</sup>/h

## STORM SERIES

High pressure fans for applications such as storage cabinets, exhaust arms, washing towers, collectors or filter boxes requiring high static pressure, and with high pressure drops.



**STORM 10**  
Flow rate : 25-200 m<sup>3</sup>/h



**STORM 12**  
Flow rate : 50-500 m<sup>3</sup>/h



**STORM 14**  
Flow rate : 400-1000 m<sup>3</sup>/h



**STORM 16**  
Flow rate : 500-1800 m<sup>3</sup>/h



Products marked with this logo are available in ATEX Zone 2 version

## JET SERIES

Incorporate the in-line assembly method. The motor is protected from the corrosive flow and the weather inside the cone. With vertical discharge, these fans are usually roof mounted.



**JET 20**  
Flow rate : 400-1600 m<sup>3</sup>/h



**JET 25**  
Flow rate : 500-3500 m<sup>3</sup>/h



**JET 30**  
Flow rate : 900-3500 m<sup>3</sup>/h



Find the right product for your project even easier, with our online selection software!

**ZEPHYR**

[www.seat-selection.com](http://www.seat-selection.com)

REMOTE HIMI CONTROLLER  
FULLY INTEGRATED CONTROLLER  
MODULAR CONTROLLER  
SAFETY OR STORAGE CABINET CONTROLLER  
ECOGLOSS  
ACCESSORIES  
EXAMPLES OF INSTALLATIONS  
THE COMPANY

## TESTIMONIALS THEY TRUST US

« In the years I have been working with SEAT Ventilation, I have never been disappointed with either the service or the products. The contact is easy and the products are of high quality. The information is clear. SEAT Ventilation's electronics expert is very efficient in guiding me through the adjustment of the control products. Very satisfied. »

**M. R. Southern Region Distributor**

« The professional relationship between our two companies dates back several years and began when SEAT Ventilation was still based in the Paris region. It is quite natural that our collaboration continued after the move to Verniolle. Indeed, the quality of the products as well as the listening and the reactivity of our interlocutors have allowed us to maintain a relationship of trust. »

**M. H. Laboratory Installer Ile de France Region**

« SEAT Ventilation is a very reactive company and very available for commercial and technical requests as well as for delivery times. The E-SEAT range is very complete. The emergency speed is a very practical feature. Reliable over time and easy to use. »

**M. G. Laboratory HVAC specialist**

« I have been working with SEAT Ventilation for more than 10 years on the maintenance and technical development of our fleet of 150 laboratory fume hoods. SEAT Ventilation provides quality products, robust and reliable over time, but also always at the cutting edge of process evolution. The whole team, managers, sales representatives and technicians, is at your disposal and shares its experience in my projects but also plays an important role in the after-sales service »

**M. V. Toulouse CNRS**

« At Vivid Air we have been using SEAT Ventilation products for almost 20 years and sell them to various industries in South Africa and surrounding countries. Their ease of use, quality and durability is exceptional. »

**Gordon - South Africa**

« We have been supplying SEAT fans and airflow controllers for 12 years. All customers are satisfied with the performance of SEAT products. They are very reliable and the quality is very good. They are able to withstand extremely harsh conditions (in the presence of corrosive chemical vapours). We will continue to recommend SEAT Ventilation products to our customers. »

**Hemal - India**

## OUR RANGE OF CONTROLLERS AT A GLANCE



All of our extraction systems have two purposes:

- > **SECURITY**
- > **FLOW CONTROL**

### INTEGRATED CONTROLS

Each controller is responsible for only one fume hood



#### Type A

- light on/off
- on-off exhaust fan
- alarms (visual and audible) in case of extraction problems.



#### Type C

- Like the Type A, and in addition allows a variable airflow according to the height of the sash, by acting on the VFD or on a motorised damper.



#### Type C 2-SPEED

- Same as the Type A, and also allows a low flow rate if the sash is lowered, or a high flow rate if the sash is raised, by acting on the VFD or on a motorised damper.

^ Each of the three models above is available as **remote** (small front panel HMI with remote CPU on top of the fume hood) or **integrated** (CPU and HMI in one piece, on the front of the fume hood).



#### CONTROL SEAT

- Only remote HMI.
- Can be operated in either Type C or Type C 2-speed mode, coupled with a linear position sensor that determines the position of the sash very precisely.

### REMOTE HMI CONTROLS

They allow you to quantitatively manage all the air extraction of your laboratory room(s) and are connected to the AHU.



#### CONTROL E-SEAT

It is a **CONTROL SEAT**, on a fume hood, which communicates with its «control tower», the CAPTUR e-SEAT.



#### L.COM E-SEAT

It is a **CONTROL E-SEAT**, but for exhaust arms and hoods.



#### CAPTUR E-SEAT

- Retrieves information from CONTROL E-SEAT and L.COM E-SEAT, i.e. from all the fume hoods and extraction arms in your laboratory room.
- Displays this information.
- Can send this information to an air handling unit, including all extract air data.

# A WORLDWIDE PRESENCE



Present on all continents, we now generate nearly half of our sales from exports.

Delivered in  
**+ THAN 80 COUNTRIES**

**+1000 CLIENTS TRUST US**

## THEY TRUST US



70 Impasse Jean Mermoz  
Parc Technologique Delta Sud  
09340 VERNIOLLE FRANCE

Tel. : +33(0)5 61 69 84 43  
Fax : +33(0)5 61 67 86 03  
Mail : [info@seat-ventilation.com](mailto:info@seat-ventilation.com)

[in](#) LinkedIn [yt](#) YouTube [fb](#) Facebook

[www.seat-ventilation.com](http://www.seat-ventilation.com)

**CETIAT member** (Centre Technique des Industries Aérauliques et Thermiques)

**FABRILABO member** (Chambre Syndicale des Fabricants et Négociants de Matériel de Laboratoire)

**AMCA International member** (Air Movement and Control Association International)

