

ROOF MOUNTED SEAT SERIES

Specifications

1 - Roof unit kit

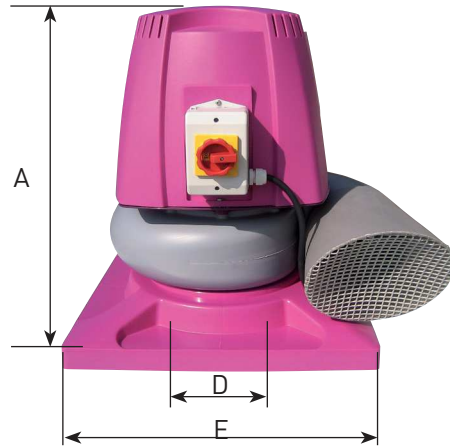

Roof unit kit includes:

- 1 Cap bracket
- 1 Motor Cap
- 1 Switcher
- 1 Roof curb bar
- 1 Exhaust Guard

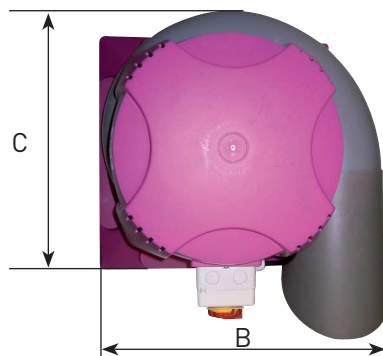

Dimensions (mm)

	A	B	C	D	E
KIT ROOF 15	550	560	560	125	547/547 int.
KIT ROOF 20	560	600	560	160	547/547 int.
KIT ROOF 25	590	680	595	200	547/547 int.
KIT ROOF 30	680	780	650	250	547/547 int.
KIT ROOF 35	880	950	850	315	700/700 int.

2 - Enclosed pedestal

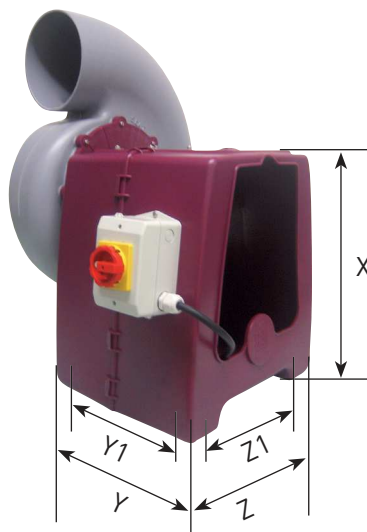

Dimensions (mm)

Fan	Type	X	Z	Y	Z1 DRILLING	Y1
SEAT 15/20/25 STORM 12/14	450	450	425	340	318	270
SEAT 25 2 P SEAT 30 STORM 16	550	550	425	340	318	270
SEAT 35	700	715	585	505	520	430

INSTALLATION PRINCIPLES

Metal stand

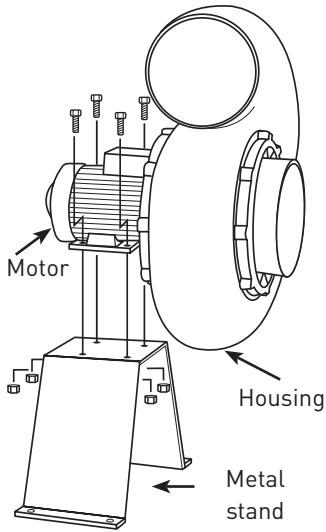

Dimensions (mm)						
Fan	A	B	C	D	E	F
SEAT 15-20	190	180	320	20	160	240
SEAT 25	190	180	400	20	160	300
SEAT 25 (2P)	190	180	400	20	160	300
SEAT 30	200	240	440	20	220	350
SEAT35	300	350	600	20	310	468

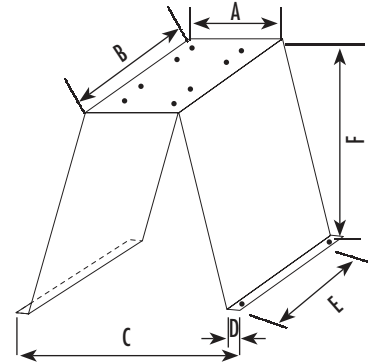

Enclosed pedestal

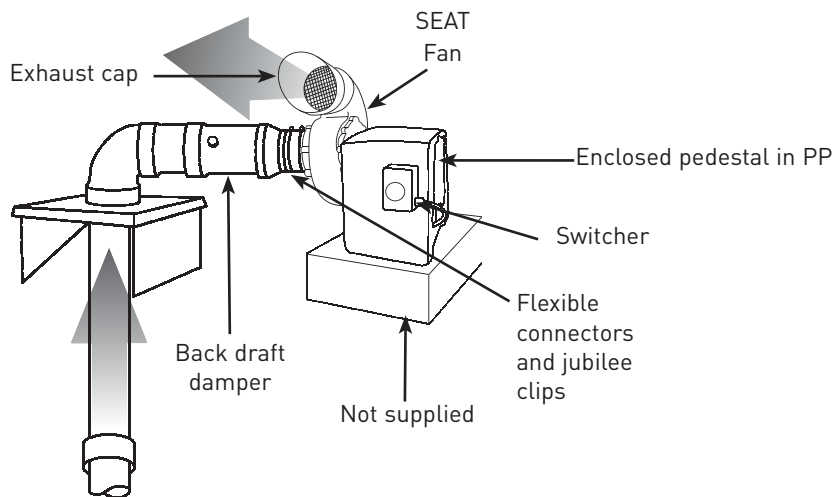

Roof unit

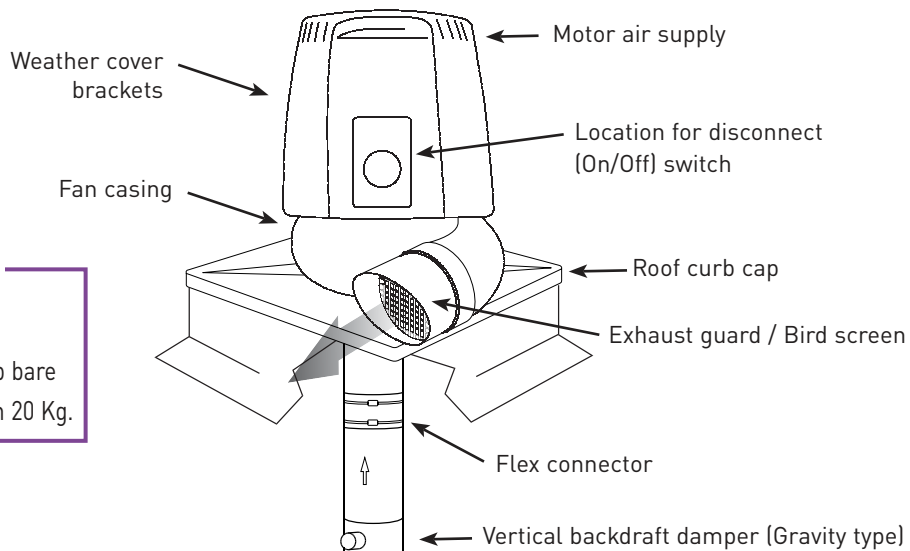

WARNING

Reinforce the base before placing the roof curb bare for a motor weight more than 20 Kg.