

# SEAT 35

PT (Pa)

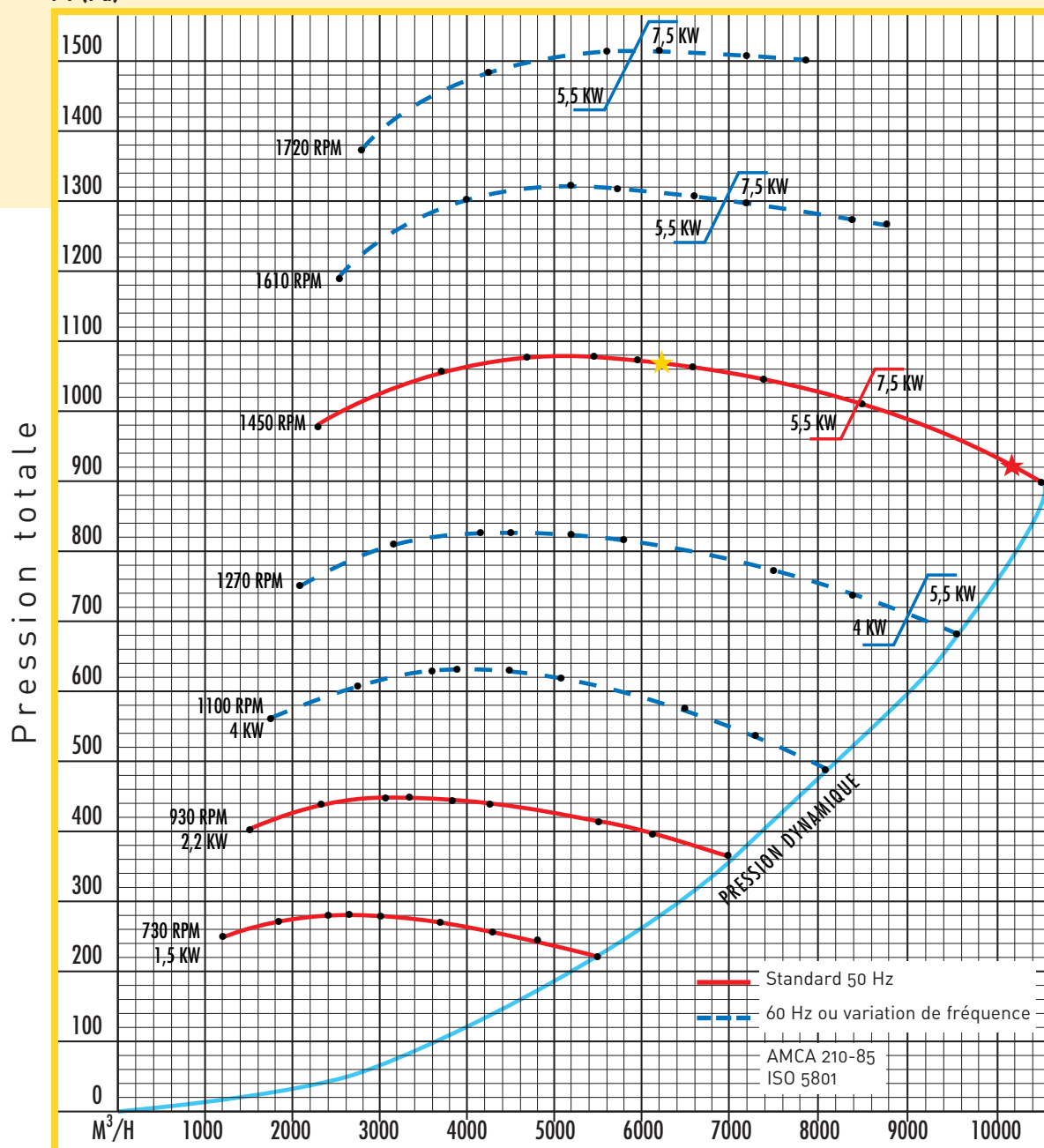

## Caractéristiques acoustiques

Type	RPM	50 Hz	100 Hz	250 Hz	500 Hz	1000 Hz	2500 Hz	5000 Hz	10000 Hz	LW Global dB
SEAT 35	1450/4 poles	68,1	65,7	68,2	68	67,4	66,7	66,8	50,3	82,4

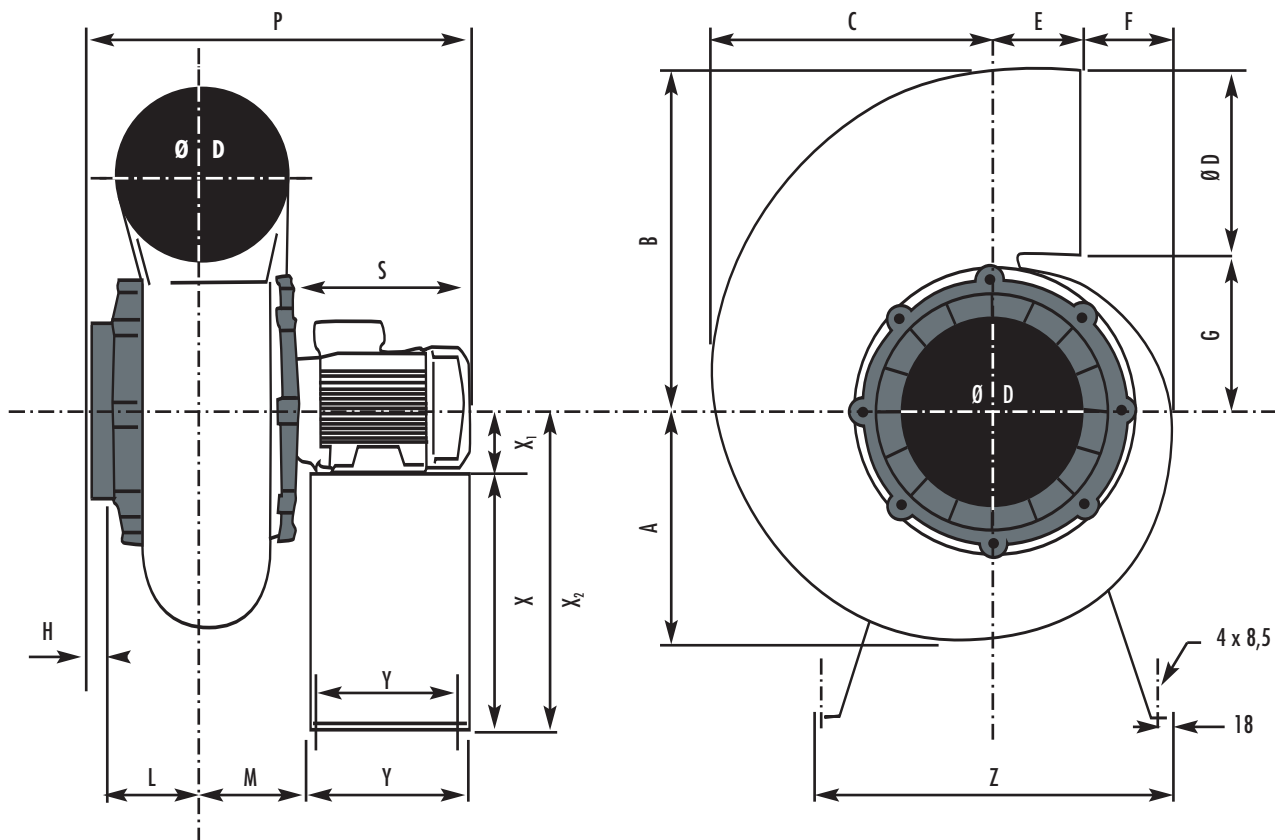

**Dimensions (mm) - Chaise métal non fournie (voir accessoires)**

**Hauteurs d'axe moteur peuvent changer selon le type de moteur utilisé**

RPM	A	B	C	Ø D	E	F	G	H	L	M	P	S	Y	Y <sub>1</sub>	Z	X	X <sub>1</sub>	X <sub>2</sub>
930	370	570	450	315	130	170	255	60	150	170	724	334	350	314	600	468	112	580
1450	370	570	450	315	130	170	255	60	150	170	792	402	350	314	600	468	112	580
1450	370	570	450	315	130	170	255	60	150	170	822	432	350	314	600	468	112	580

**Positions de montage - Vues côté aspiration**



LG 0



LG 45



LG 90



LG 135



LG 180



LG 225



LG 270



LG 135