

SEAT 25

PT (Pa)

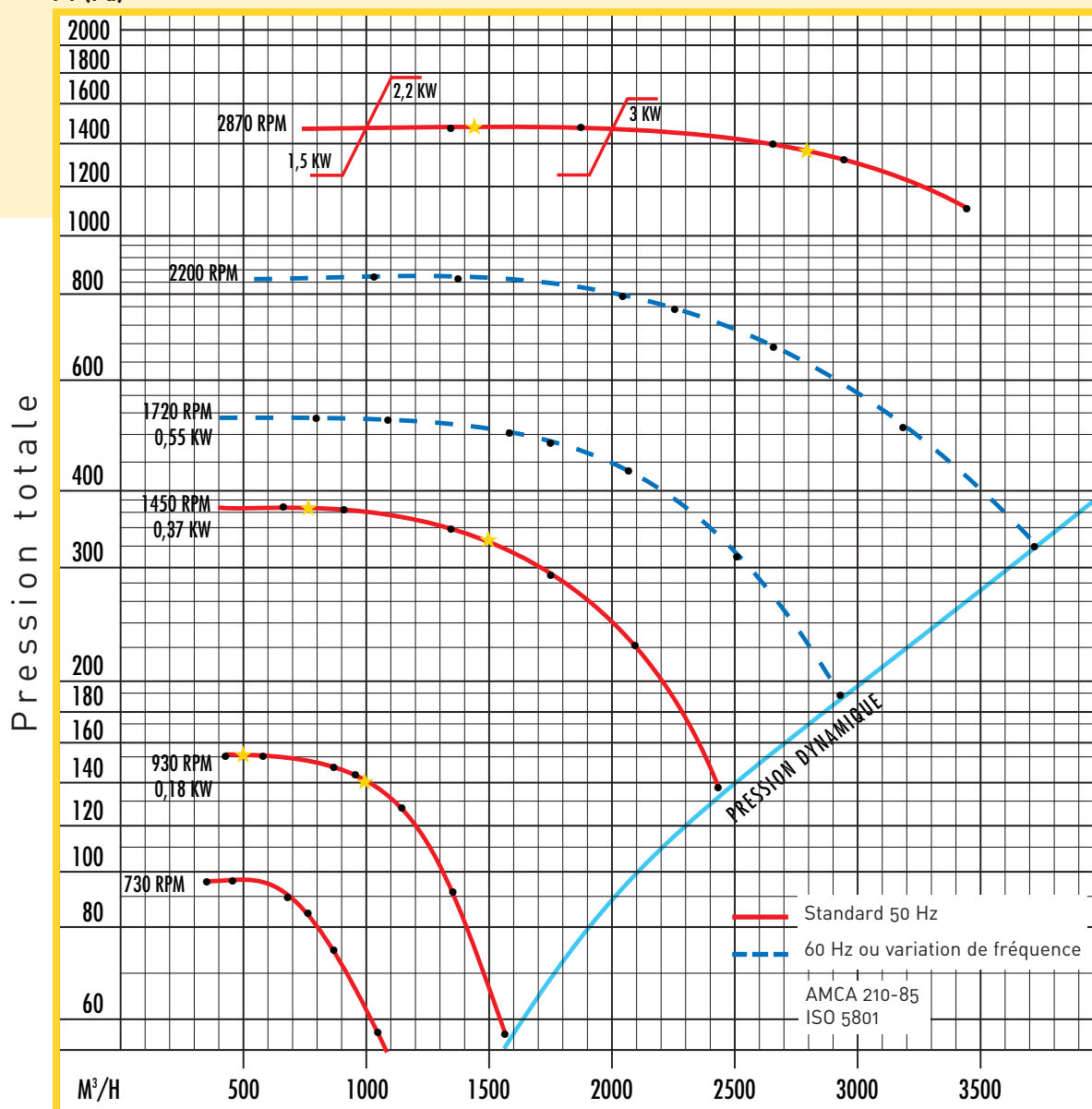

Caractéristiques acoustiques

Type	RPM	63 Hz	125 Hz	250 Hz	500 Hz	1000 Hz	2000 Hz	4000 Hz	8000 Hz	LW Global dB(A)
SEAT 25	950/6 poles	43	57	54	53	56	46	41	32	44
	1450/4 poles				62	66	55	52	46	54
	2850/6 poles	62	84	78	74	85	70	68	66	71

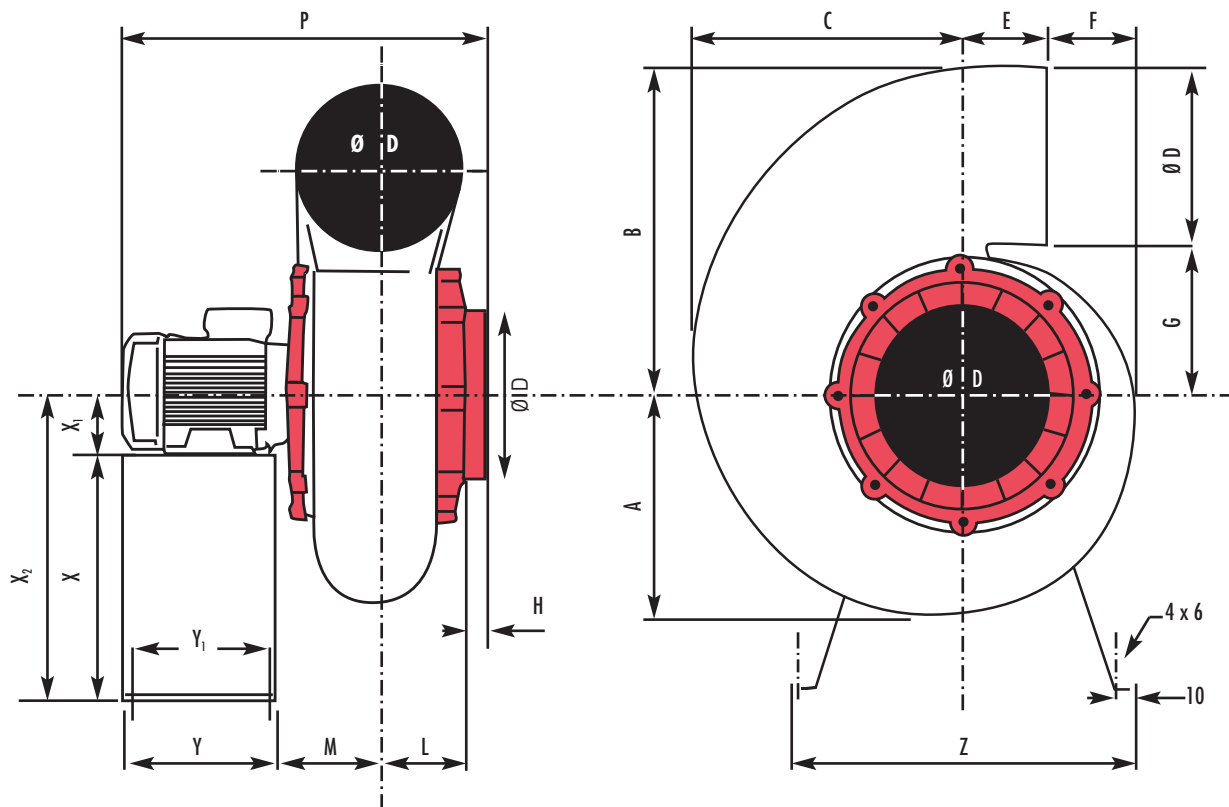

Dimensions (mm) - Chaise métal non fournie (voir accessoires)

Hauteurs d'axe moteur peuvent changer selon le type de moteur utilisé

RPM	A	B	C	Ø D	E	F	G	H	L	M	P	Y	Y ₁	Z	X	X ₁	X ₂
930 / 1450	248	365	310	200	103	92	165	35	95	105	430	180	160	420	300	71	371
2870	248	365	310	200	103	92	165	35	95	105	515	180	160	420	300	90	390

Positions de montage - Vues côté aspiration



LG 0



LG 45



LG 90



LG 135



LG 180



LG 225



LG 270



LG 135



RD 0



RD 45



RD 90



RD 135



RD 180



RD 225



RD 270



RD 135