

SEAT 20

Série SEAT

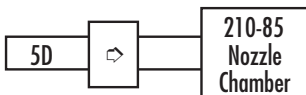

Type B
LW Mesure Puissance Acoustique

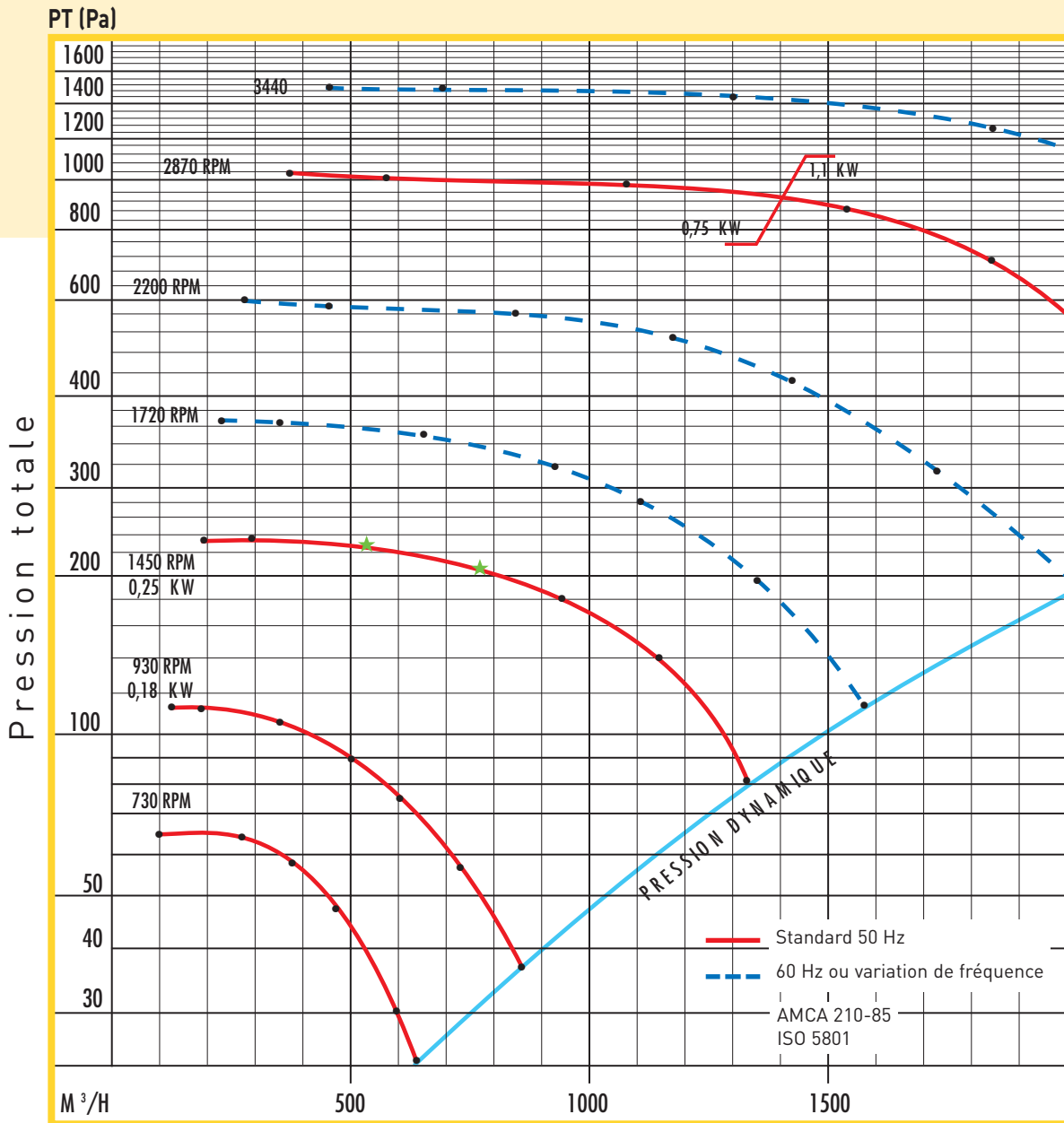

n (T/min) R.P.M.	dB(A)		dB	
950	53	54	61	62
★ 1450	65	66	70	71
2870	83	84	85	86

n (T/min) R.P.M.	dB (A)	
950	41	42
1435	51	52
2870	66	67

Mesures acoustiques selon ISO 9614/1

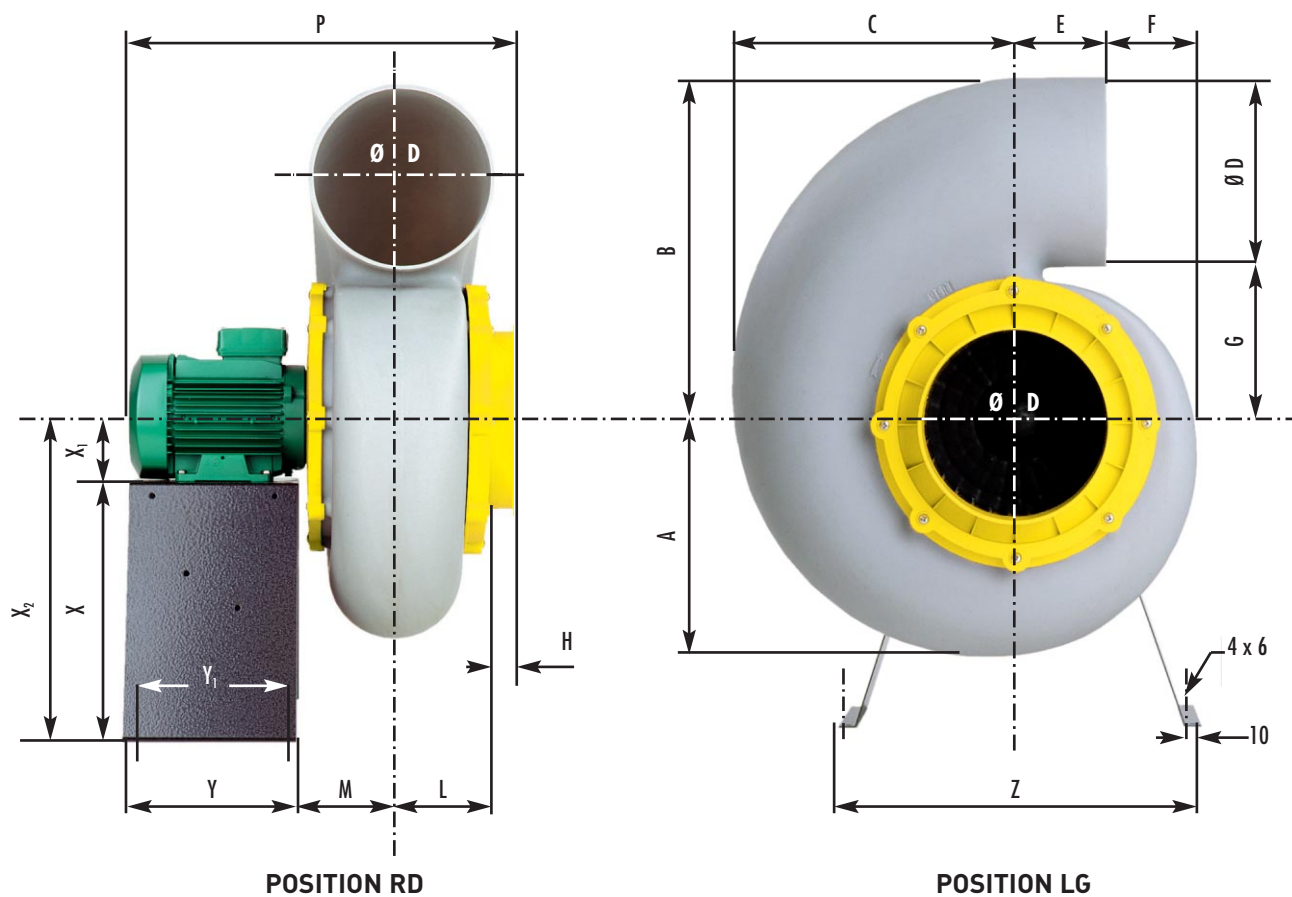

SEAT 20

Dimensions (mm) - Chaise métal non fournie (voir accessoires)																
A	B	C	Ø D	E	F	G	H	L	M	P	Y	Y ₁	Z	X	X ₁	X ₂
208	303	240	160	100	57	143	32	84	94	390	180	160	340	240	71	311

ATTENTION : pour un montage sur une chaise haute protection, X₂ = 370 mm.

Positions de montage - Vues côté aspiration							
LG 0	LG 45	LG 90	LG 135	LG 180	LG 225	LG 270	LG 315
RD 0	RD 45	RD 90	RD 135	RD 180	RD 225	RD 270	RD 315