

SEAT 15

Série SEAT

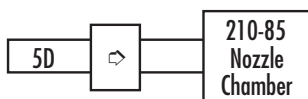
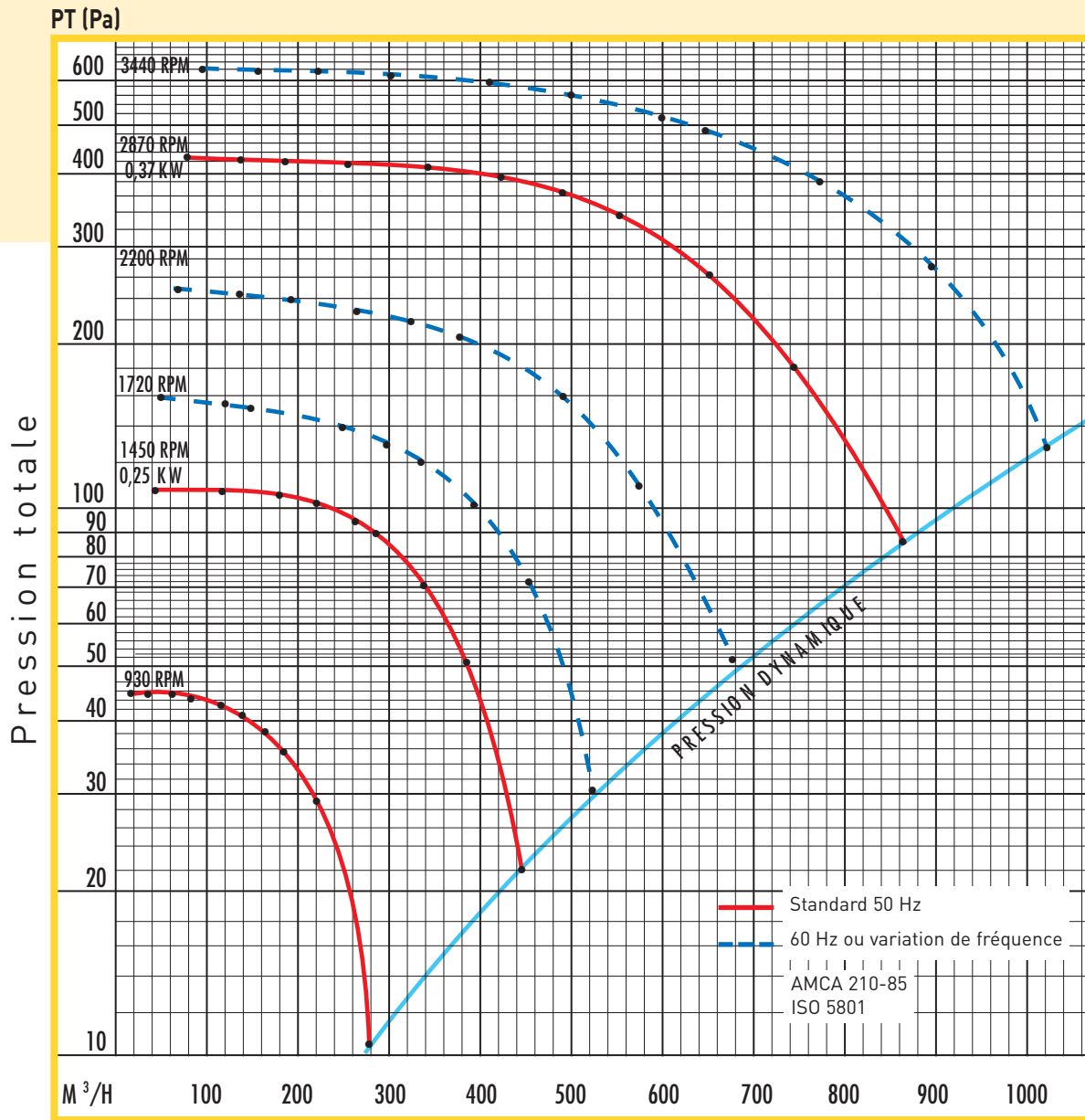

Type B
LW Mesure Puissance Acoustique

n (T/min) R.P.M.	dB (A)		dB	
1450	52	54	57	59
2870	70	71	72	74



Type D
Bruit d'enveloppe

n (T/min) R.P.M.	dB (A)
1435	49
2870	63

Mesures acoustiques selon ISO 9614/1

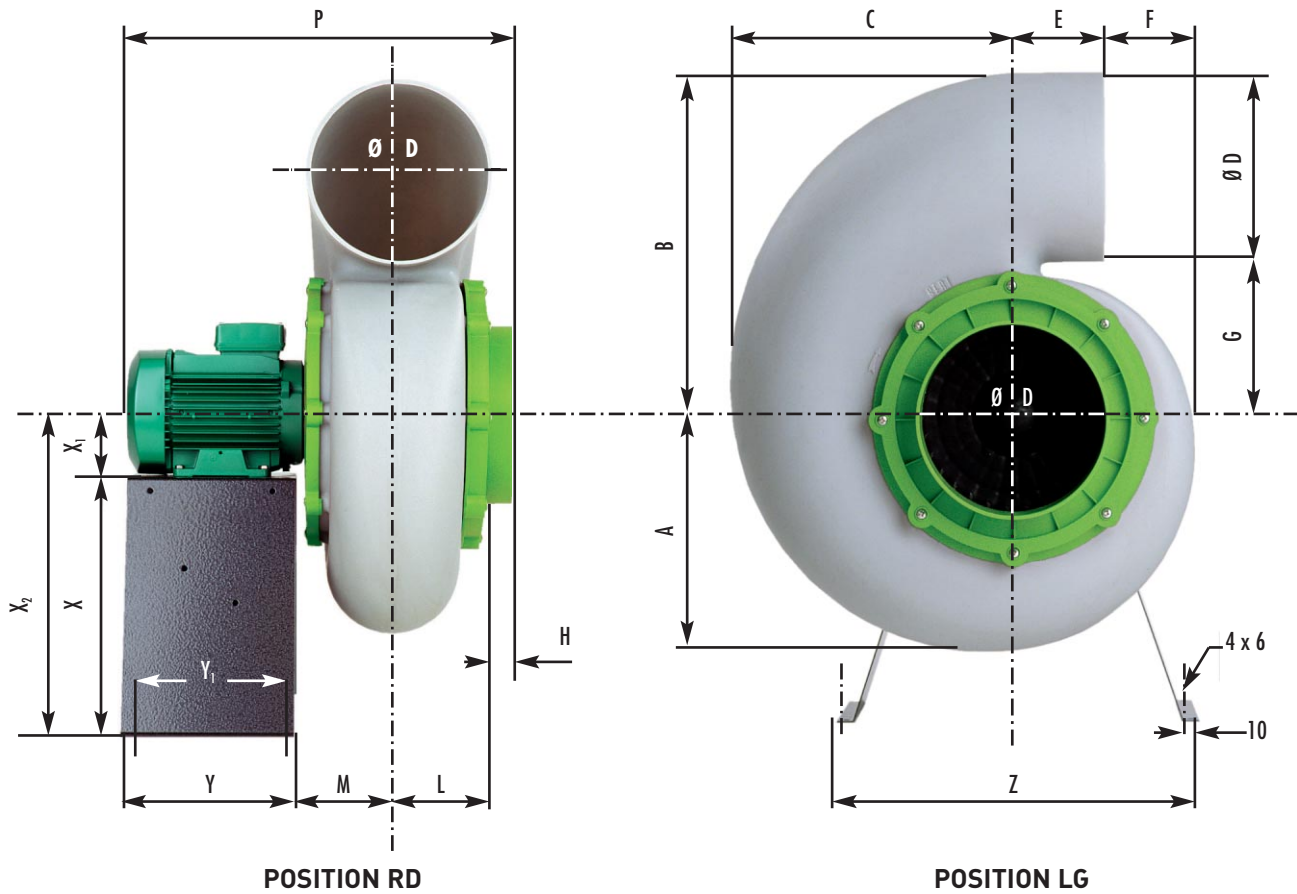

SEAT 15

Dimensions (mm) - Chaise métal non fournie (voir accessoires)																
A	B	C	Ø D	E	F	G	H	L	M	P	Y	Y ₁	Z	X	X ₁	X ₂
170	240	203	125	100	32	115	30	70	80	360	180	160	340	240	71	311

ATTENTION : pour un montage sur une chaise haute protection, X₂ = 370 mm.

Positions de montage - Vues côté aspiration							
LG 0	LG 45	LG 90	LG 135	LG 180	LG 225	LG 270	LG 315
RD 0	RD 45	RD 90	RD 135	RD 180	RD 225	RD 270	RD 315